

W H Y T E  
P E R F O R M A N C E B Y D E S I G N

DESIGNED IN THE UK	PAGES 3-4
RESEARCH AND DEVELOPMENT	PAGES 5-6
WHYTE GEOMETRY	PAGES 7-8
MATERIALS	PAGES 9-10
RACING	PAGES 11-12
FULL SUSPENSION	PAGES 13-14
T-129	PAGES 15-20
M-109	PAGES 21-26
G-150	PAGES 27-30
WHYTE ADJUSTABLE DROPOUT/ GETTA GRIP	PAGES 31-32
TRAIL HARDTAILS	PAGES 33-38
X8 PERFORMANCE HARDTAILS	PAGES 39-44
X4 KID'S PERFORMANCE HARDTAIL	PAGES 45-48
29ER CARBON HARDTAILS	PAGES 49-54
X29 PERFORMANCE HARDTAILS	PAGES 55-60
LC7 LIGHTWEIGHT CLASSIC	PAGES 61-64
C7 ALL TERRAIN	PAGES 65-72
R7 FAST URBAN	PAGES 73-80
RD7 ROAD DISC	PAGES 81-86
CX CYCLO CROSS	PAGES 87-90
WHYTE WHEELS	PAGES 91-92
WHYTE PARTS AND ACCESSORIES	PAGES 93-94
GEOMETRY AND SPECIFICATIONS	PAGES 95-98
SPECIFICATIONS	PAGES 99-108



## DESIGNED IN THE UK AND PROVEN ON THE UK'S TOUGHEST TRAILS

Since the inception of Whyte in 1999, we have delivered on the insistent mantra of performance by design. Cutting edge developments have earned us numerous bike test awards and rave reviews internationally on an annual basis ever since. But, in the run-up to our 2014 range it's clear that the latest paradigm shift in bike design has come from Whyte and it has led to the most critically acclaimed year in our history, culminating in the prestigious UK Trail Bike of the Year Award.

It's something we're very proud of here at Whyte and it's the reason you'll never find us standing still.

Pushing the accepted design and performance limits is something we are proud to achieve. Having a small design team makes us fast on our feet and responsive to both slowly evolving and instantly revolutionary new technology developments. It means we build the bikes we all want to ride, now.

So while our new 2014 line is the biggest ever, we've lost none of that critical focus. Our bikes handle better, last longer and cope with our uniquely challenging riding conditions here in the UK, a UK that's just had its wettest and coldest Spring in 50 years.

Now, even more riders like you - and like us - can find their perfect bike in our 2014 range.













## RESEARCH AND DEVELOPMENT

PERFORMANCE BY DESIGN



Our R&D address might be in the Cotswolds, but our real test facilities are city streets and mountain trails all over the world.

We work out multi piece carbon lay ups through riding countless laps of Welsh trail centres but have them verified by our race team as far away as the dry riverbeds of Botswana. Our geometry is fractionally exact because we know it makes us faster and gives us more control, not because we've taken an average of what others have done. We confidently put a lifetime warranty on our suspension bearings, because we grind them through the same grit and grime you have to for thousands of hours a year. A CAD machine might make the final rendering, but that big lever on our unique seat clamp is there because we got sick of trying to shut a normal one with frozen fingers. We know the addition of Crud Catcher mounts to our mountain bike frames is a significant one for all of us, because it means our eyes sting less after our lunchtime ride and our tea isn't washing grit off our teeth.

We could go on, but you get the idea. Whyte are genuinely a small group of dedicated UK riders, determined to produce the best bikes we can and not afraid to break some rules and set some benchmarks along the way.









## WHYTE GEOMETRY

### MUCH MORE THAN JUST NUMBERS

More than anything, the frame geometry of a bike defines its personality and determines how it will behave in different situations. Here at Whyte, we're more than a little obsessive about it.

More than a decade's evolution on the UK's trails and roads has led us to ours; a perfectly balanced, confidence-inspiring feel that encourages and rewards the rider in equal measure, whatever their level of skill.

For a beginner, that might mean handling that is always stable and predictable, whatever the terrain. For an intermediate rider it could mean taking a new, more challenging line on a familiar trail - or for an expert, the ability to push harder and faster than ever before.

### THE WHYTE DIFFERENCE

Our relaxed head angle and longer front-centre gives increased stability at speed - especially on steeper descents. A wider bar and shorter stem sharpens up the steering response for slow speed precision. We aim for as short a rear-centre as possible as this gives more agility - allowing the rider to pop and boost through the gnarliest trail obstacles.





## MATERIALS SELECTED FOR CONSISTENCY AND LONGTERM PERFORMANCE

We make frames from Aluminium and Carbon Fibre as both of these materials have their own specific properties and their own particular ride characteristics.

Whether we are looking to create the super-stiff structure required for a full suspension bike or the lively yet comfortable ride that characterises a top quality alloy hardtail frame, all the materials we use must have one thing in common - they have to be the best available. Only then can we be sure we are achieving the best possible combination of strength and light weight and that the resulting frame will achieve the benchmark performance required by us and our customers.

## ALUMINIUM CUSTOM TUBING FOR LIGHT-WEIGHT STRENGTH AND SUPERIOR RIDE FEEL

For our aluminium trail frames, we use perhaps the ultimate refinement of aluminium alloy frame materials - specifically developed for use in hydro-forming and welded frame construction and custom drawn to our specification. Our selection of premium 6061 grades of aluminium allows us to specify tubes of thinner wall section. This translates into thinner tube butting profiles over the entire length of the tubes and means that for the same strength, stiffness and fatigue characteristics we can engineer a lighter chassis.

Whyte hydro-formed aluminium frame designs concentrate on creating the best, most efficient shapes for the chassis. Our seatstays and chainstays have extensive shaping and tapering to increase strength and stiffness generating volume where it's needed, providing maximum mud clearance at key areas of the frame, as well as producing a frame that has a clean, elegant overall design profile and offers discernible comfort benefits in use.

## WHYTE CARBON TECHNOLOGY TAILORED FOR A PERFECT RIDE

The performance of any carbon fibre component relies on three things - the quality of the raw material, the integrity of the design and the precision of the assembly. That's why at Whyte, we take complete control of the design process and then work closely with the world's best carbon manufacturers to bring our designs to life.

This close working relationship also means we can develop special combinations of filament grades and resin types to give our carbon frames a genuine performance advantage that others can't match, combined with reliable performance you can trust.











## WHYTE RACING PERFORMANCE BY DESIGN - PROVEN IN COMPETITION

Anyone can throw their shirt on the latest shaven legged wonder and win some races. We prefer our athletic ambassadors to be a little more real though. OK, so the speed global racer Luke Smith will come past you is scarcely believable. The relentless hour-after-hour velocity of multiple Enduro, Polaris and Trans Wales winner Steve Heading isn't good for others egos either. However their performance and passion is both an inspiration and an ideal development tool for us.



These racers all clock up their victories and rack up training miles on proper tough technical trails and courses. They live and thrive in conditions where several seconds gained on a descent repeated thirty times in 24 hours are worth far, far more than a few shaved grams. Where consistently sure-footed traction and rock solid power transfer enable you to clean climbs all the way to the top of a podium as effectively as they do in the Peak District. It's the reason our geometry is radically different from the standard, default XC template that's held back racers for years.

In other words we support racing that translates directly to you going further, faster and having more fun every time you ride. The durable and lightweight frames we produce have pioneered a new era of race geometry which enables our athletes to hammer technical trails harder for longer. Our innovative and still unique 29er geometry has reset expectations of how well a bigger wheeled bike can handle.

Since Whyte has become the technical equipment supplier to the well respected Torq-Whyte Mountain Bike team, we have transferred the Whyte philosophy of design and development into real world race winning results at the highest level and the team remain an invaluable part of our development and testing process.









## QUAD 4 - WHYTE FULL SUSPENSION

When we set out to design a suspension system appropriate for 29er and 650b we knew it had to be very different. With our design and development solely focussed in the unique environment of UK trail riding, nothing currently available was able to meet our benchmark combination of progressive, contemporary frame geometry with year-round weatherproof reliability, a hereditary no-compromise Quad-Link suspension feature.

Larger wheels and full suspension; we quickly realised that the bike's geometry, the suspension kinematics and architectural layout needed to be integrated together to a far higher fidelity than anyone has ever achieved to date. Keeping the rear of the bike as compact and stiff as possible with the same dynamic ride response of a 26" bike, means minimising the distance between the rear wheel and bottom bracket centres - no mean feat on a bigger wheel suspension bike, but one of the fundamentals to Whyte's unique handling elixir. On its own a hugely significant dimension, but together with a complete approach to mountain bike geometry, resulted in Mountain Biking Australia proclaiming that the new QUAD-4 suspension platform has "pioneered a new era of progressive genre-defining 29er full suspension bikes."

We break new ground whilst covering it faster and smoother than you'd believe possible.









## W H Y T E T - 1 2 9 29ER TRAIL SUSPENSION

What more can be said or written about this bike? The UK Trail Bike of the Year Award winner, critically acclaimed from Bath to Brisbane. Key to the T-129's success is Whyte's correctly proportioned geometry with the shortest chainstay length in the industry, meaning genuine progressive trail bike geometry for the 29er full-suspension age.

Climb, carve, descend - the T-129 will also hold incredible speed in technical sections that would previously have you grabbing a fist full of brake. These bikes are guaranteed to put a massive grin on your face, and leave others trailing in your wake.

For 2014 we have enhanced the frame and expanded the range to include a new T-129 Works specification.



**"BEST GEOMETRY, SPEC  
AND HANDLING, THE  
WHYTE T-129 IS THE  
STANDOUT PACKAGE  
IN THIS TEST"**



**"FUSS-FREE SUSPENSION  
AND TOP VALUE KIT  
PRODUCE FANTASTIC FLOW  
AND MAKE THE WHYTE OUR  
CLEAR WINNER."**

# T-129 WORKS

TYPICAL USAGE: TRAIL

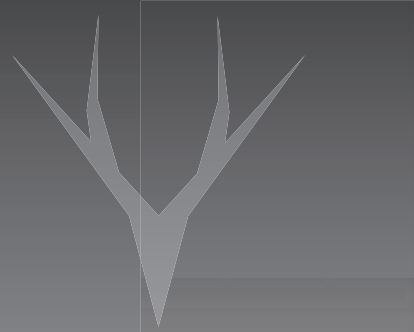

■ The Works is a new addition to the award winning T-129 line. A benchmark spec of Hope/Shimano XT and Fox suspension gives you year-round durability for whatever the UK weather throws at you. ■ Lifetime warranty bearings are used throughout the design, giving this bike exceptional durability in the harshest UK conditions. ■ Speed and flow is the name of the game with the T129 range. Keep off the brakes as long as you dare, tip the bike in as hard as you can and try and work out how you have tamed your favourite single track so fast.

**Spec highlights:** Fox Performance Suspension / Shimano XT 2 by 10 groupset / Shimano XT I-Spec brakes and shifters.

## 29ER 120MM SUSPENSION: T-129 WORKS



# T-129 S

TYPICAL USAGE: TRAIL



■ Our Quad 4 suspension layout allows us to apply our contemporary 29er Trail hardtail geometry to the 120mm suspension Trail bike category. Short chainstays gives this bike the agility of a 650b/27.5" wheel bike but with the inertia and terrain flattening advantages of a larger 29er wheel. ■ Reverb Stealth seat post, WTB TCS tubeless-ready tyres and rims and Whyte's all new cockpit finishing with ultra-wide 750mm bars and gravity short stem are just a few of the standout spec of the T-129 S. ■ Speed and flow is the name of the game with the T129 range. Keep off the brakes as long as you dare, tip the bike in as hard as you can and try and work out how you have tamed your favourite single track so fast. **Spec highlights:** RockShox Reba fork, Reverb Stealth seatpost / WTB TCS (tubeless ready) rims and tyres / SRAM X-9 / Avid Elixir 5 Matchmaker set up.

29ER 120MM SUSPENSION: T-129 S

T-129

TYPICAL USAGE: TRAIL



■ Our Quad 4 suspension layout allows us to apply our contemporary 29er Trail hardtail geometry to the 120mm suspension Trail bike category. Short chainstays gives this bike the agility of a 650b/27.5" wheel bike but with the inertia and terrain flattening advantages of a larger 29er wheel. ■ Lifetime warranty bearings are used throughout the design, giving this bike exceptional durability in the harshest UK conditions. ■ Speed and flow is the name of the game with the T129 range. Keep off the brakes as long as you dare, tip the bike in as hard as you can and try and work out how you have tamed your favourite single track so fast. **Spec highlights:** RockShox Reba RL fork with custom-tuned Monarch RL rear shock / 29er Trail gear ratios (36-22) / Short stem with 750mm wide handle bar.

## 29ER 120MM SUSPENSION: T-129













## M - 1 0 9

### 29ER CROSS COUNTRY/MARATHON SUSPENSION

Once again, Whyte's correctly proportioned geometry with the shortest chainstay length in the industry means genuine progressive 26" style geometry for the 29er full-suspension age.

One ride on our early hand built prototype and we knew we were onto something very special with the M-109. Minutes, not seconds carved off our benchmark test loops. Incredible control, remarkable momentum and outstanding traction. By far, the most accomplished XC bike we have built and a one that encouraged our test riders to go further and harder than ever before.

Major grouptest wins and international critical acclaim followed in 2013. For 2014 we have applied our new carbon technology to the M-109 front triangle allowing us to create an even lighter more nimble XC and marathon full suspension 29er.

# M-109 C TEAM

TYPICAL USAGE: CROSS COUNTRY/MARATHON



■ The M-109-C Team is the ultimate Marathon/Endurance ride in our 100mm travel line. Designed for long, high-speed days in the saddle. Our Quad 4 suspension delivers efficiency and reliability, built around lifetime pivot bearings for smooth operation today and forever - guaranteed. ■ The new carbon front triangle reduces weight, as does the all-new XC-209-C Team wheelset. These next generation carbon wheels from Whyte use wide, low-profile 23mm tubeless-ready carbon rims. ■ Shimano XTR parts combined with an XT 29er ratio chainset and Fox Racing's Factory suspension gives you the benchmark spec for a Marathon bike.

**Spec highlights:** Fox Factory suspension / Whyte XC-209-C Team wheelset / Shimano XTR / XT drive-train with 29er gear ratios 40-30-22.

## 29ER 100MM SUSPENSION: M-109 C TEAM



# M-109 S

TYPICAL USAGE: CROSS COUNTRY/MARATHON



■ Conceived as the ideal Marathon/Endurance ride, our award winning 100mm travel M-109 bikes are designed for long, high-speed days in the saddle. No faster way to get from A to B XC under your own power. ■ Lifetime warranty bearings are used throughout the design, giving this bike exceptional durability, in the harshest UK conditions. ■ Whyte's own design XC-209C Carbon Wheelset guarantees excellent acceleration and manoeuvrability. For 2014 the rims are upgraded to 23mm wide Tubeless ready.

**Spec highlights:** Fox Performance suspension / Whyte XC-209-C wheelset / Shimano XT drive-train with 29er gear ratios 40-30-22.

## 29ER 100MM SUSPENSION: M-109 S

# M-109

TYPICAL USAGE: CROSS COUNTRY/MARATHON



■ Conceived as the ideal Marathon/Endurance ride, our "Award Winning" 100mm travel M-109 bikes are designed for long, high-speed days in the saddle. Our Quad 4 suspension layout creates room for a larger 29" wheel and is built around lifetime bearings for smooth operation today and forever - guaranteed. ■ Whyte's 29er XC geometry keeps the back of the bike as short as possible, uniquely combining 26" agility with 29er momentum for speed and control. ■ The M-109 combines Whyte's XC-209 custom wheelset and Maxxis, high air volume Ikon tyres for an exceptional lightweight wheel package - essential for a nimble feel on any 29er. **Spec highlights:** Shimano SLX drive-train with 29er gear ratios 40-30-22 / Shimano SLX / Deore I-Spec brakes and shifters / Whyte XC-209 wheelset with welded rims.

## 29ER 100MM SUSPENSION: M-109













## G - 1 5 0

### 650b/27.5" GRAVITY ENDURO/TRAIL SUSPENSION

The best of both worlds. Add some of the terrain flattening abilities of a 29er wheel to the agility of a smaller 26" wheel and the result is 650b. 18 months of extensive R&D testing using this wheel size has allowed us to unlock a new level of performance and capability in a 150mm trail bike, all built around our uniquely radical geometry and award-winning QUAD 4 suspension.

Faster, stronger and more agile - the G-150 is the bike that takes Whyte's QUAD-4 suspension into the Gravity Enduro arena.

# G-150 WORKS

TYPICAL USAGE: GRAVITY ENDURO/TRAIL



■ The G-150 is new for 2014. 150mm travel and 650b/27.5" wheels makes this platform perfect for Gravity Enduro racing or just bombing around your local hardcore trails. ■ Lifetime warranty bearings are used throughout the design, giving this bike exceptional durability in the harshest UK conditions. ■ The G-150 Works has SRAM's latest version of their revolutionary 1 by 11 drivetrain. This new X01 group has all the features of the XX1 group but uses alloy crank arms. The G-150 is all about suspension and the Works is fitted with the best, FOX Factory spec with Kashima coating. **Spec highlights:** Fox Factory Suspension with Kashima coating / SRAM X01 1 BY 11 drive-train / SRAM Rail wheelset 23mm UST rims.

## 650B/27.5" 150MM SUSPENSION: G-150 WORKS



G-150

TYPICAL USAGE: GRAVITY ENDURO/TRAIL

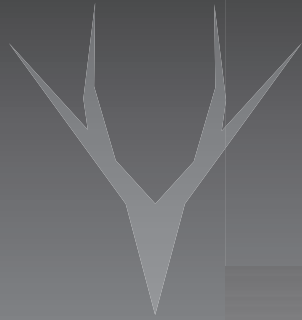

■ The G-150 is new for 2014. 150mm travel and 650b/27.5" wheels makes this platform perfect for Gravity Enduro racing or just bombing around your local hardcore trails. ■ Lifetime warranty bearings are used throughout the design, giving this bike exceptional durability in the harshest UK conditions. ■ 23mm wide TCS Tubeless ready rims and tyres, combined with the new RS Pike fork make this bike ready for anything you want to throw at it. The rear Wolverine tyre is specced with Inner Peace side wall protection for that extra security through rocky sections.

**Spec highlights:** RockShox PIKE RC fork with custom tuned Monarch RT3 rear shock / RockShox Reba Reverb Stealth seat post / SRAM X-9/Avid Elixir 7 Trail Matchmaker set up.

650B/27.5" 150MM SUSPENSION: G-150

## WHYTE ADJUSTABLE DROPOUT

AS FEATURED ON THE WHYTE 909

As you might expect from Whyte not even something as simple as the rear dropout is left without a magic touch from our designers. Our unique dropout system provides geometry adjustment as well as easy conversion to a single speed setup.

The CNC machined rear dropouts allow a plus or minus 10mm adjustment of the chainstay length from the zero centre position. With the chainstay length increased the bike sits slightly lower giving a more relaxed feel to the ride and providing more stability on steep, technical descents. Shortening the chainstay length raises the bottom bracket height slightly for increased ground clearance, improved climbing and sharper handling in tight, twisty singletrack.

Both dropout plates are engraved with markings to make accurate wheel alignment quick and easy and the stepless adjustment is perfect to accurately tension the chain for a single speed or hub gear set up with no need to adjust the brake caliper.

## GETTA GRIP

AS FEATURED ON THE T-129, M-109, G-150, 909

Getta Grip has been developed from scratch to improve the way a seatpost is held in the frame. Traditional clamps need to bend the frame to grip the seat post and often bind after long periods of use, as the frame can no longer "remember" its original shape.



The Patented Getta Grip system takes a whole new approach using a pad that fits through a window in the frame - ideal for UK conditions as there is no open slot to let in mud and water. Because the Getta Grip seat clamp only has to hold the seatpost rather than bend the frame, less force is required to operate it. The clamping force is spread more evenly making it ideal for carbon posts and has been officially approved by Easton for use with all their seatposts.











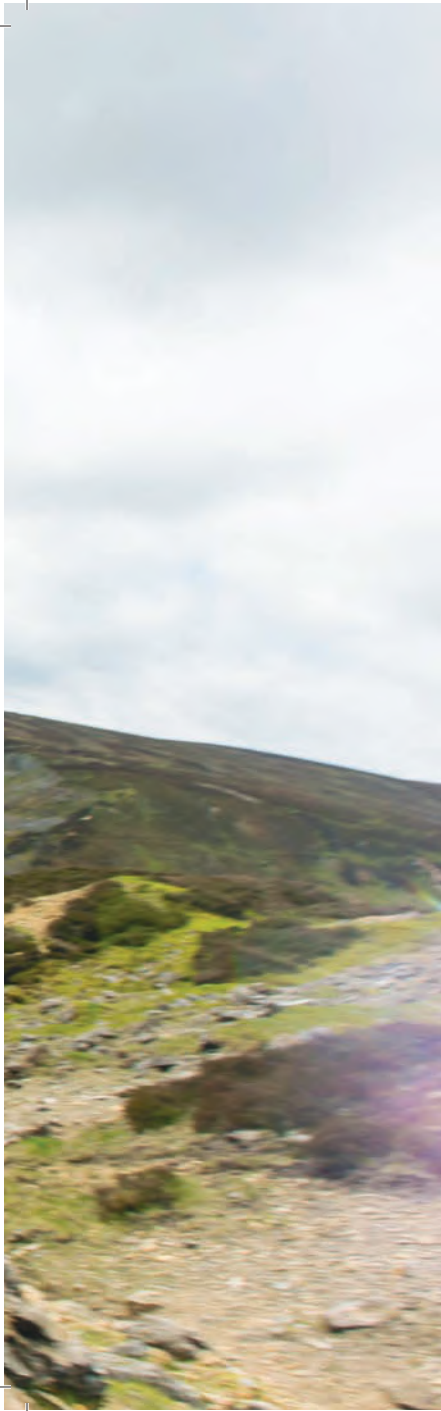

## TRAIL HARDTAILS

### 650b/27.5" TRAIL

How do you improve on a classic? The challenge facing the design team was to do just that with the 2014 Whyte Trail Hardtail - and we have. Our work with the 650b / 27.5" wheelsize has allowed us to improve traction, grip and roll-over performance. Combined with our progressive, slack, short chainstay, low BB design geometry these new bikes have true trail bike balance and our best ever handling.

2014 is a watershed moment for Whyte's genre defining range of Trail Hardtails.

909

TYPICAL USAGE: TRAIL



- The 909 is new to the line and uses an all new 650b/27.5" frameset but the wheel size is not the only change; the new 900 series geometry takes Whyte's latest thinking on trail geometry and implants it into the DNA of this bike.
- The 909 has SRAM's latest version of their revolutionary 1 by 11 drivetrain. This new X01 group has all the features of the XX1 group but uses alloy crank arms. Benchmark Shimano XT brakes, provide the anchors.
- Mud clearance and all weather features have long been associated with our designs and when Whyte set out to design this 650b/27.5" frame there was no exception. We have fitted our unique adjustable dropouts, so you can run the chainstays short in the summer and longer in the winter for more mud clearance or singlespeed if that's your thing. **Spec highlights:** Fox Performance suspension / SRAM X01 1 BY 11 drive-train / Shimano XT brakes.

## 650B/27.5" TRAIL HARDTAIL: 909



905

TYPICAL USAGE: TRAIL



WHYTE  
PERFORMANCE BY DESIGN



■ The 905 gets an all new 650b/27.5" frameset in 2014 but the wheel size is not the only change; the new 900 series geometry takes Whyte's latest thinking on trail geometry and implants it into the DNA of this bike. ■ The frame is constructed from the highest quality 6061 aluminium alloy, extruded and manipulated to our exact specification. ■ The cockpit parts combine with the geometry to give maximum control, a 750mm wide bar and Whyte's new short, wide mouthed, Gravity stem add huge stiffness and precision.

**Spec highlights:** RockShox Revelation RL fork / Shimano SLX / Deore I-Spec brakes and shifters / Hope rear hub.

650B/27.5" TRAIL HARDTAIL: 905







901

TYPICAL USAGE: TRAIL



- The 901 gets an all new 650b/27.5" frameset in 2014 but the wheel size is not the only change; the new 900 series geometry takes Whyte's latest thinking on trail geometry and implants it into the DNA of this bike.
  - The frame is constructed from 6061 aluminium alloy, extruded and manipulated to our exact specification. The 901 gains a fraction more travel and stiffness with the 130mm Sektor Gold fork.
  - The cockpit parts combine with the geometry to give maximum control, a 750mm wide bar and Whyte's new short, wide mouthed, Gravity stem add huge stiffness and precision.
- Spec highlights:** RockShox Sektor Gold fork / Whyte 21mm trail rims / Maxxis optimized tyre choice.

650B/27.5" TRAIL HARDTAIL: 901









## X 8 : P E R F O R M A N C E H A R D T A I L S

### 650b/27.5" CROSS COUNTRY/TRAIL

The Performance XC Hardtail series offer a perfect introduction to the Whyte brand. Available in both unisex and women's specific models, they are constructed of light weight butted aluminium with geometry derived from our acclaimed carbon hardtails and built for thrashing in tough UK conditions. 100mm forks, 2.2 tyres, wide low-rise bars and short stems create an XC trail ready ride that is both responsive and thrilling to ride. Whether you are riding your local woods, lining up for your first race grid or setting the pace with friends at the trail centre this range is going to deliver.

For 2014 we have further improved our XC performance hardtails with a redesign around 650b/27.5" wheels, combining some of the terrain flattening abilities of a larger 29er wheel with the agility of a smaller 26" wheel. The same confidence inspiring progressive handling now rides faster and smoother with enhanced grip and control.

806

TYPICAL USAGE: CROSS COUNTRY



■ The 806 geometry is designed with a slightly shorter top tube and a little more standover height to offer a better fit for women. For 2014 there is a brand new high quality 650b/27.5" frameset which features on all the X-8 bikes. The custom tubing is drawn to our specification and then profiled, butted and shaped to give what we consider to be the perfect ride feel. ■ These frames bristle with UK design features, such as extra mud clearance for all-weather usability, forward facing seat slot to keep rear wheel spray out of the frame, continuous outers for improved cable life and crud-catcher mounts on the downtube to keep the grit out of your teeth. ■ Shimano 10 speed drive train, with shorter 170mm cranks and women's anatomic saddle complete the package. This bike is also Tubeless ready so no need to worry about punctures.

**Spec highlights:** Shimano 3 by 10 groupset, with 170mm crank arms / RockShox XC-30 fork / Light weight wheel package.

## WOMEN'S 650B/27.5" XC HARDTAIL: 806



805

TYPICAL USAGE: CROSS COUNTRY



WHYTE  
PERFORMANCE BY DESIGN



■ For 2014 there is a brand new high quality 650B/27.5" frameset which features on all the X-8 bikes. The custom tubing is drawn to our specification and then profiled, butted and shaped to give what we consider to be the perfect ride feel. ■ Our trail-honed geometry is both fast and reassuring, encouraging you to push your limits on the descents as well as the climbs. ■ These frames bristle with UK design features, such as extra mud clearance for all-weather usability, forward facing seat slot to keep rear wheel spray out of the frame, continuous outers for improved cable life and crud-catcher mounts on the downtube to keep the grit out of your teeth. **Spec highlights:** RockShox XC-30 Gold Fork with alloy tapered steerer tube / SRAM 3 by 10 groupset / Avid Elixir 1 brakes.

650B/27.5" XC HARDTAIL: 805

802

TYPICAL USAGE: CROSS COUNTRY



WHYTE  
PERFORMANCE BY DESIGN



■ The 802 geometry is designed with a slightly shorter top tube and a little more standover height to offer a better fit for women. For 2014 there is a brand new 650b/27.5" high quality frameset which features on all the X-8 bikes. The custom tubing is drawn to our specification and then profiled, butted and shaped to give what we consider to be the perfect ride feel. ■ These frames bristle with UK design features, such as extra mud clearance for all-weather usability, forward facing seat slot to keep rear wheel spray out of the frame, continuous outers for improved cable life and crud-catcher mounts on the downtube to keep the grit out of your teeth. ■ Shimano 9 speed drive train, with shorter 170mm cranks and women's anatomic saddle complete the package. **Spec highlights:** SR Suntour XCR 100mm travel fork with alloy steerer tube / Shimano Octalink bottom bracket and crankset.

WOMEN'S 650B/27.5" XC HARDTAIL: 802



801

TYPICAL USAGE: CROSS COUNTRY



WHYTE  
PERFORMANCE BY DESIGN



■ For 2014 the 801 gets our all new 650b/27.5" frameset which features on all our XC performance hardtails. The custom tubing is drawn to our specification and then profiled, butted and shaped to give what we consider to be the perfect ride feel. ■ These frames bristle with UK design features, such as extra mud clearance for all-weather usability, forward facing seat slot to keep rear wheel spray out of the frame, continuous outers for improved cable life and crud-catcher mounts on the downtube to keep the grit out of your teeth.

**Spec highlights:** Shimano 3 by 9 groupset / Shimano Octalink bottom bracket and crankset / SR Suntour XCR 100mm travel fork with alloy steerer tube.

650B/27.5" XC HARDTAIL: 801









## X4: KID'S PERFORMANCE HARDTAIL 26" CROSS COUNTRY/TRAIL

Take a 24" wheel kid's MTB and design a bike for 9-13 year old kids - that was our brief. However, we decided to apply the same theory with bigger, easier rolling wheels by upping the 24" wheels to 26". Result: a kid's bike that rides like an adult's 29er. More confidence, more control and easier, safer riding. The real plus here is the upgrade potential thanks to Mum or Dad's 26" MTB hand-me-downs!

401

TYPICAL USAGE: CROSS COUNTRY/TRAIL



■ The 401 is the first Kid's bike we've made. Driven by our passion for high-speed bikes we decided to ditch the usual route of making a 24" wheel bike and instead we have created a 26er with a 13" frame. So now your son or daughter can keep up with you on your Whyte 29er. ■ These frames bristle with UK design features, such as extra mud clearance for all-weather usability, forward facing seat slot to keep rear wheel spray out of the frame, continuous outers for improved cable life and crud-catcher mounts on the downtube to keep the grit out of your teeth. ■ SRAM's X0 10-speed Grip Shift combined with a 1 by 10 drivetrain gives a totally up-to-date set up. SRAM's Type 2 rear mech keeps the chain under control and a chainguard keeps little fingers safe. **Spec highlights:** SR Suntour Raidon 100mm travel fork with alloy steerer tube / SRAM X0 10 speed Grip Shift / SRAM X-7 Type 2 rear clutch derailleur.

## KID'S XC HARDTAIL: 401







## 29ER CARBON HARDTAILS

TYPICAL USAGE: CROSS COUNTRY/RACE

Carbon fibre design detail is critical as there is often potential for constant improvements and gains. The fundamental philosophy of our frame follows an OverSize/UnderSize chassis design where the frame is hugely oversize in areas critical for tracking and power transfer, yet minimal and under-size where comfort needs to be engineered.

The 29-C frames have a big update in 2014. A new lighter headtube with integrated headset design shaves weight, with further optimised carbon layup in this critical area of the frame. We have also used internal routing inside the TT to improve cable management and clean up the aesthetics and design presentation of the frames. With the unchanged and unparalleled geometry, unique ride performance and amazing critical success, the 29-C range is one of Whyte's flagship products.







## 29-C TEAM

TYPICAL USAGE: CROSS COUNTRY/RACE



■ We have taken all our experience in award winning hardtail designs and applied the same unique formula to our 29ers to deliver perfect balance and control. ■ Our unique Whyte frame geometry is more surefooted than a typical light-weight XC race bike, inspiring confidence on more technical sections. ■ Whyte's brand new Team unidirectional high modulus carbon wheels are stiff, light, Tubeless Ready and have wide 23mm rims making the 29-C Team even faster off the line and out of corners.

**Spec highlights:** Fox Factory suspension / Whyte XC-209-C Team wheelset with 23mm carbon rims (tubeless ready) / Shimano XT I-Spec brakes and shifters.

## CARBON HARDTAIL: 29-C TEAM





29-C S

TYPICAL USAGE: CROSS COUNTRY/RACE



■ We have taken all our experience in award winning hardtail designs and applied the same unique formula to our 29ers to deliver perfect balance and control. ■ Our unique Whyte frame geometry is more surefooted than a typical light-weight XC race bike, inspiring confidence on more technical sections. ■ With a Tapered steerer tube, 15mm Maxle Lite front wheel interface and the excellent Whyte XC-209-C wheelset, this bike will not only get you round your favourite XC loop in a record breaking time, it will also give you the control and balance of the very best of our Whyte trail bikes. **Spec highlights:** Whyte XC-209-C wheelset with 23mm carbon rims (tubeless ready) / Shimano XT / SLX drive-train with FSA Press Fit 30 SL-K carbon crankset, 29er XC gear ratio 38-24 / RockShox SID RL fork with remote lock-out.

CARBON HARDTAIL: 29-C S



29-C

TYPICAL USAGE: CROSS COUNTRY/RACE

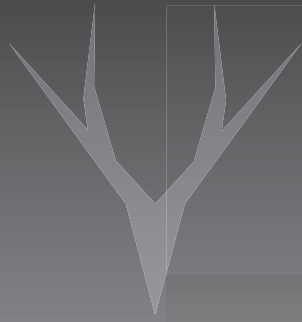

■ We have taken all our experience in award winning hardtail designs and applied the same unique formula to our 29ers to deliver perfect balance and control. ■ Our unique Whyte frame geometry is more surefooted than a typical light-weight XC race bike, inspiring confidence on more technical sections. ■ Lightweight wheels are essential to 29er performance. Whyte's XC-229-S rims combined with CNC machined hubs give a real performance benefit. The front hub features oversize 28mm flanges to increase the front end stiffness.

**Spec highlights:** RockShox REBA RL fork with lock-out / Press Fit 30 SRAM crankset with 2 by 10, 29er XC gear ratio 38-24 / SRAM X-9 Type 2 rear derailleur.

CARBON HARDTAIL: 29-C

# X 2 9 P E R F O R M A N C E H A R D T A I L S

## 29" C R O S S C O U N T R Y / T R A I L

We've brought our progressive geometry ideas to our 29" hardtails.

In design terms that means closely mirroring our Carbon 29-C frames in the development of the X-29 series. This has resulted in one of the most confidence-inspiring 29ers available in a performance 100mm alloy hardtail setup. Simply put, it means a faster and a more controlled ride, built with the changeable UK climate in mind.

bikemagic.com described the 729 as "a bike handling dream: lightweight and sturdy under foot, it simply flows through the trails and will keep any trail hungry novice, or experienced rider grinning from ear-to-ear"

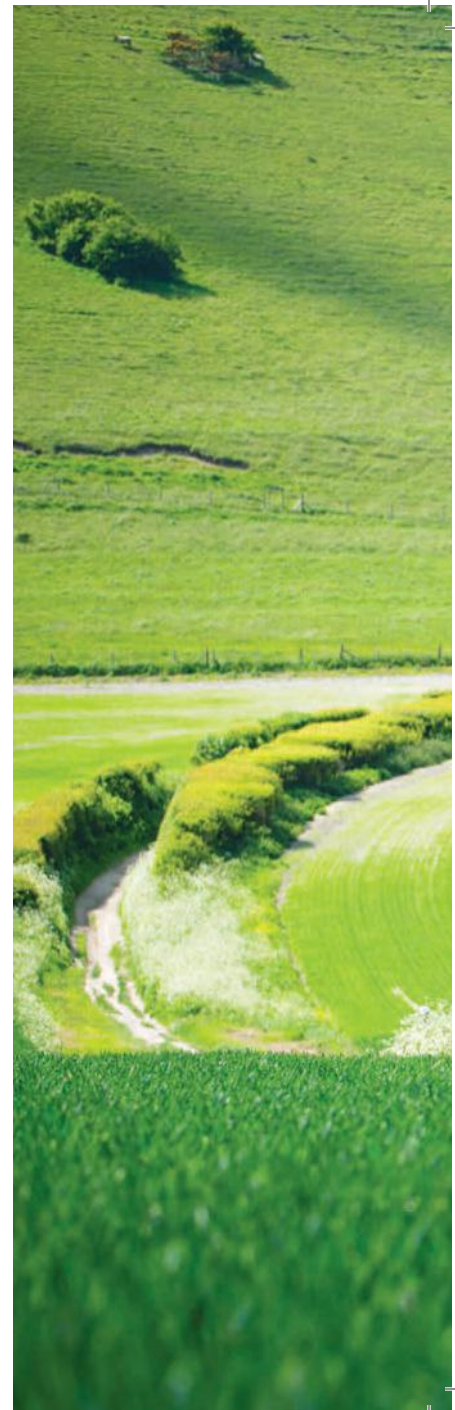







729

TYPICAL USAGE: CROSS COUNTRY/TRAIL



■ The same high quality frameset features on all the X-29 bikes. The custom tubing is drawn to our specification and then profiled, butted and shaped to give what we consider to be the perfect ride feel. ■ The X-29 geometry is based on the ground breaking 29-C frame. The unique Whyte combination of XC speed, Trail bike handling and all-day comfort bring some thing very special to the 29er movement. ■ These frames bristle with UK design features, such as extra mud clearance for all-weather usability, forward facing seat slot to keep rear wheel spray out of the frame, continuous outers for improved cable life and crud-catcher mounts on the downtube to keep the grit out of your teeth. **Spec highlights:** RockShox REBA RL fork with lock-out / Whyte XC-209 wheelset with welded rims / SRAM X-9/Avid Elixir 7 Trail Matchmaker set up.

29ER PERFORMANCE HARDTAIL: 729



629

TYPICAL USAGE: CROSS COUNTRY/TRAIL



■ The same high quality frameset features on all the X-29 bikes. The custom tubing is drawn to our specification and then profiled, butted and shaped to give what we consider to be the perfect ride feel. ■ The X-29 geometry is based on the ground breaking 29-C frame. The unique Whyte combination of XC speed, Trail bike handling and all-day comfort bring some thing very special to the 29er movement. ■ These frames bristle with UK design features, such as extra mud clearance for all-weather usability, forward facing seat slot to keep rear wheel spray out of the frame, continuous outers for improved cable life and crud-catcher mounts on the downtube to keep the grit out of your teeth. **Spec highlights:** RockShox XC-30 fork with alloy tapered steerer tube and oversize hub interface / Whyte XC-229 sleeve joint rims / Avid Elixir 1 brakes.

29ER PERFORMANCE HARDTAIL: 629

529

TYPICAL USAGE: CROSS COUNTRY/TRAIL



■ The same high quality frameset features on all the X-29 bikes. The custom tubing is drawn to our specification and then profiled, butted and shaped to give what we consider to be the perfect ride feel. ■ The X-29 geometry is based on the ground breaking 29-C frame. The unique Whyte combination of XC speed, Trail bike handling and all-day comfort bring some thing very special to the 29er movement. ■ These frames bristle with UK design features, such as extra mud clearance for all-weather usability, forward facing seat slot to keep rear wheel spray out of the frame, continuous outers for improved cable life and crud-catcher mounts on the downtube to keep the grit out of your teeth. **Spec highlights:** RockShox XC-28 Gold fork / Shimano 3 by 9 groupset / Shimano Octalink bottom bracket and crankset.

## 29ER PERFORMANCE HARDTAIL: 529











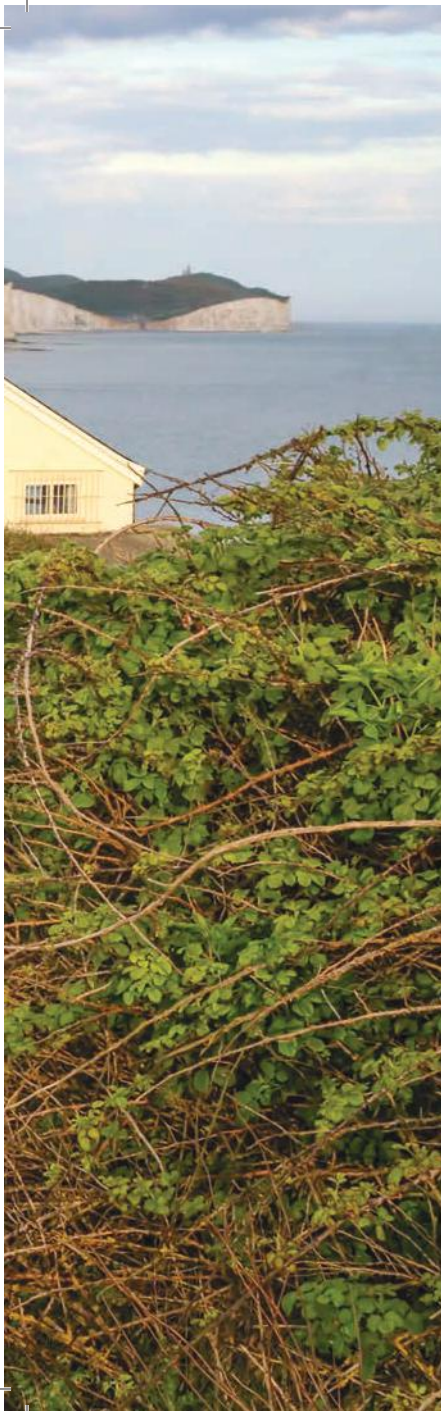

## LC7: LIGHTWEIGHT CLASSIC

### COMFORT AND STYLE

The Strawberry Hill is Whyte's take on a lifestyle bike. Style with comfort is clearly the aim but we also wanted to add a technical solution, so that this bike could handle hills and headwinds without drama. A 30-speed Shimano drive train concealed behind a full chain guard gives you performance with elegance and our highly evolved lightweight frame delivers an amazing ride quality.





# STRAWBERRY HILL

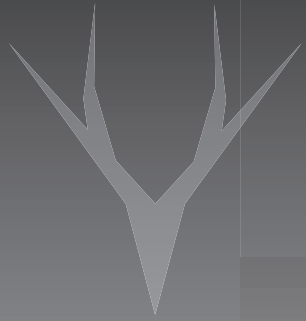

■ The Strawberry Hill is Whyte's take on a lifestyle bike. Stylish is clearly the aim but we also wanted to add a technical solution, so that this bike could handle hills and headwinds without drama. A 30-speed Shimano drive train concealed behind a full chain guard gives you performance and elegance. ■ Comfort was given top priority, with the Strawberry Hill, the Stella Royal Milo saddle is very comfortable but also lightweight. The grips from Ergo are designed to fit your palm on a swept handle bar bike and even the brake levers have a kraton insert to add a tactile and comfortable feel. ■ Full mudguards, a chainset cover and internal cable routing keep all the moving parts away from the rider. **Spec highlights:** Alloy triple butted frame / Alloy fork with alloy Steerer / Shimano 3 by 9 groupset.

## LC7: STRAWBERRY HILL









## C 7 : A L L T E R R A I N S E R I E S

### VERSATILITY WITH COMFORT AND STYLE

This range is where Whyte 29" MTB design ideas dove-tail with the classic European style Trekking bike, resulting in off-road performance and style, combined with a functional do-anything chassis and parts spec. You'll find clean frame design with all cables and hoses out of the way and low maintenance hydraulic disc brakes with puncture-resistant tyres on every model.

A lifestyle performance all-rounder that really delivers from the city street to the country trail.

# CALEDONIAN WOMEN'S

TYPICAL USAGE: ALL TERRAIN



- All the same key design features as the men's version, with the added benefit of a partially dropped top tube. This increases standover height, while still keeping enough room inside the frame to comfortably fit a water bottle.
  - Another benefit of the partially dropped tube is the maintained stiffness of the frame (fully dropped top tube frames are flexy and offer less steering control).
  - Full Shimano 9 speed Deore with Octalink BB interface for MTB durability.
- Spec highlights:** SR Suntour NCX fork with hydraulic lockout and alloy steerer tube / Shimano 3 by 9 groupset / Puncture resistant all-terrain tyres.

## C7: CALEDONIAN WOMEN'S



# MALVERN WOMEN'S

TYPICAL USAGE: ALL TERRAIN



- All the same key design features as the unisex version, with the added benefit of a partially dropped top tube. This increases standover height, while still keeping enough room inside the frame to comfortably fit a water bottle.
  - Another benefit of the partially dropped tube is the maintained stiffness of the frame (fully dropped top tube frames are flexy and offer less steering control).
  - Full Shimano 9 speed group to give years of unrivalled performance and puncture resistant tyres for extra reliability and piece of mind.
- Spec highlights:** SR Suntour NEX fork with hydraulic lockout / Puncture resistant all-terrain tyres / Ergonomic, Whyte lock-on triple density comfort grips.

## C7: MALVERN WOMEN'S

# CHILTERN

TYPICAL USAGE: ALL TERRAIN



■ When we set out to create a range of bikes that would handle all-terrain use we started with the geometry of the frame. 13 years of off-road experience told us that these bikes first and foremost needed to handle sweetly, whether riding along a canal tow path, heading down a woodland trail, or beating the traffic on the way through town. ■ A custom rear drop out allows us to fit the hydraulic disc brake calliper inside the rear triangle leaving you plenty of room to fit a rack and mudguards if desired. ■ Full Shimano 10 speed using the Deore/XT Trekking groupset for unbeatable performance and reliability. **Spec highlights:** Shimano 3 by 10 groupset / Hollow Tech II crankset with 48-38-26 gear ratios / Double wall and eyeleted rims with DT Swiss spokes.

## C7: CHILTERN





# CALEDONIAN

TYPICAL USAGE: ALL TERRAIN



■ Our custom built frames are loaded with unique design touches and British weatherproof features - such as the forward facing seat slot that stops water spray from the rear wheel getting into the frame and the continuous outer cables that keep the gear shifting working smoother for longer. ■ The ride-feel of these bikes is second to none, with a fantastic quality lightweight frame including our unique rear seat stays which really improve the comfort and performance, whatever the terrain. ■ Full Shimano 9 speed with a SLX Shadow rear derailleurs and Octalink BB interface for MTB levels of durability. **Spec highlights:** Shimano 3 by 9 groupset / SR Suntour NCX fork with hydraulic lockout and alloy steerer tube / Shimano 446 hydraulic brakes.

## C7: CALEDONIAN



# MALVERN

TYPICAL USAGE: ALL TERRAIN



■ Our custom built frames are loaded with unique design touches and British weatherproof features - such as the forward facing seat slot that stops water spray from the rear wheel getting into the frame and the continuous outer cables that keep the gear shifting working smoother for longer. ■ The ride-feel of these bikes is second to none, with a fantastic quality lightweight frame including our unique rear seat stays which really improve the comfort and performance, whatever the terrain. ■ Full Shimano 9 speed group to give years of unrivalled performance and puncture resistant tyres for extra reliability and piece of mind. **Spec highlights:** Shimano 3 by 9 groupset / SR Suntour NEX fork with hydraulic lockout / Double wall and eyeleted rims.

## C7: MALVERN

## R 7 : F A S T U R B A N S E R I E S

### U R B A N C O M M U T E R

Whyte has redefined the Urban Flatbar Commuter bike with the R7 series. Combining the best elements of an Urban MTB, the immediate power delivery of a road bike and the design flair of a Single Speed. Clean, smooth frame design aesthetics with all cables and hoses out of the way, low maintenance hydraulic disc brakes and puncture-resistant tyres on every model.

A British concept for the Great British Commute.







# PIMLICO

TYPICAL USAGE: URBAN COMMUTER



■ Based on our high performance mountain bike geometry, the Pimlico has a long wheelbase and relaxed head angle for high speed stability, a shorter stem for excellent slow speed manoeuvrability and slightly shorter and lower top tube to fit a women's physique better. ■ A custom rear dropout allows us to mount the rear hydraulic disc brake calliper inside the rear triangle, clearing the way for any rack or mudguards that may be required. ■ The Pimlico takes advantage of SRAM's Via Centro groupset, specifically designed for urban riding with optimised ratios and slightly wider Q factor for a little more heel clearance. **Spec highlights:** Kevlar beaded tyres with puncture resistance belt / Ladies fit saddle and 170mm crank arms / Carbon fibre bladed fork.

## WOMEN'S R7: PIMLICO



# VICTORIA

TYPICAL USAGE: URBAN COMMUTER



■ Based on our high performance mountain bike geometry, the Victoria has a long wheelbase and relaxed head angle for high speed stability, a shorter stem for excellent slow speed manoeuvrability and slightly shorter and lower top tube to fit a women's physique better. ■ A custom rear dropout allows us to mount the rear hydraulic disc brake calliper inside the rear triangle, clearing the way for any rack or mudguards that may be required. ■ Our shaped, butted and uniquely profiled rear stays give all our fast Urban bikes a fantastically responsive and comfortable ride.

**Spec highlights:** Kevlar beaded tyres with puncture resistance belt / Whyte R-7 deep section rims with 3M reflective decals / Ladies fit saddle and 170mm crank arms.

## WOMEN'S R7: VICTORIA

# MONTPELLIER

TYPICAL USAGE: URBAN COMMUTER

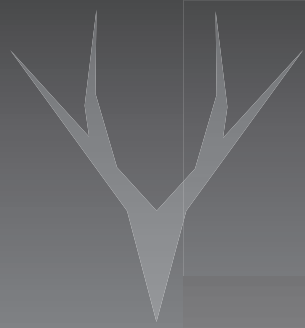

■ The Montpellier uses a full carbon RC-7 frame and fork. We have incorporated our "Oversize/Undersize" approach from our carbon hardtails to give great power delivery away from the lights, but with class leading comfort. ■ Based on our high performance mountain bike geometry, the Montpellier bridges the gap between out-right road speed and MTB control, with its long wheelbase and relaxed head angle for high speed stability, and a shorter stem for excellent slow speed manoeuvrability. ■ The Montpellier takes advantage of SRAM's Via GT groupset, specifically designed for Urban riding with optimised ratios and slightly wider Q factor for a little more heel clearance. **Spec highlights:** SRAM Via GT 2 by 10 groupset / Whyte R-7 deep section rims with 3M reflective decals / Ergon GP1 grips.

## R7: MONTPELLIER



# STIRLING

TYPICAL USAGE: URBAN COMMUTER

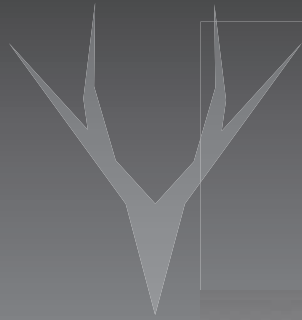

- Based on our high performance mountain bike geometry, the Stirling has a long wheelbase and relaxed head angle for high speed stability, and a shorter stem for excellent slow speed manoeuvrability.
  - A custom rear dropout allows us to mount the rear hydraulic disc brake calliper inside the rear triangle, clearing the way for any rack or mudguards that may be required.
  - The Stirling takes advantage of SRAM's Via GT groupset, specifically designed for urban riding with optimised ratios and slightly wider Q factor for a little more heel clearance.
- Spec highlights:** SRAM Via GT 2 by 10 groupset / Ergon GP1 custom grips / Avid DB-1 disk brakes.

## R7: STIRLING

# CAMBRIDGE

TYPICAL USAGE: URBAN COMMUTER



- Based on our high performance mountain bike geometry, all our Fast Urban bikes have a long wheelbase and relaxed head angle for high speed stability, and a shorter stem for excellent slow speed manoeuvrability.
  - A custom rear dropout allows us to mount the rear hydraulic disc brake calliper inside the rear triangle, clearing the way for any rack or mudguards that may be required.
  - The Cambridge takes advantage of SRAM's Via Centro groupset, specifically designed for urban riding, with optimised ratios and slightly wider Q factor for a little more heel clearance.
- Spec highlights:** Carbon fibre bladed fork / SRAM Via Centro 2 by 10 groupset / Whyte R-7 deep section rims with 3M reflective decals.

## R7: CAMBRIDGE



# PORTOBELLO

TYPICAL USAGE: URBAN COMMUTER



- Based on our high performance mountain bike geometry, all our Fast Urban bikes have a long wheelbase and relaxed head angle for high speed stability, and a shorter stem for excellent slow speed manoeuvrability.
  - A custom rear dropout allows us to mount the rear hydraulic disc brake calliper inside the rear triangle, clearing the way for any rack or mudguards that may be required.
  - Our shaped, buffed and uniquely profiled rear stays give all our Fast Urban bikes a fantastically responsive and comfortable ride.
- Spec highlights:** Hydraulic brakes / Lock-on security skewers / Whyte R-7 deep section rims with 3M reflective decals.

## R7: PORTOBELLO

## RD7: ROAD DISC DROP BAR COMMUTER/ANYROAD

Whyte are already established pioneers in modern fast-urban bicycle design and we have further developed our ideas to produce the ultimate cross-over road bike. Longer Commutes? Grand-Touring? Winter Road Training? It's all covered with the RD-7 series.

Disc brakes deliver improved control with year-round reliability and our own take on classic road geometry results in supreme versatility. If your commute is 10 miles rather than 10 minutes, you need a fast, durable all-round tool for the job. Whyte has made you that bike.







# SUFFOLK

TYPICAL USAGE: COMMUTER/ANYROAD



■ A strong alloy 6061 frame, with mudguard and rack eyelets combined with deep section R-7 wheels and disk brakes will give years of reliable all-season performance. ■ Whether you're commuting longer distances, winter training or entering summer sportives, the Whyte road disk range offers Cyclo Cross durability with pure road geometry. ■ Shimano 105 drive train with 34-50 compact gearing gives a great spread of gear ratios, whether commuting fully loaded or winter training, while TRP's HyRd hydraulic brakes give you all-weather control.  
**Spec highlights:** TRP HyRd Hydraulic brakes / Shimano 105 groupset / Whyte R-7 deep section Rims with 3M reflective decals.

## RD7: SUFFOLK



**DORSET**  
TYPICAL USAGE: COMMUTER/ANYROAD



■ A strong alloy 6061 frame, with mudguard and rack eyelets combined with deep section R-7 wheels and disk brakes will give years of reliable all-season performance. ■ Whether you're commuting longer distances, winter training or entering summer sportives, the Whyte road disk range offers Cyclo Cross durability with pure road geometry. ■ Shimano Tiagra 10 speed drive train with 34-50 compact gearing gives a great spread of gear ratios, whether commuting fully loaded or winter training.

**Spec highlights:** Shimano Tiagra groupset / Pro Max mechanical disk brakes with linear, Kevlar-reinforced full length outer cables / Whyte R-7 deep section rims with 3M reflective decals.

**RD7: DORSET**

# SUSSEX

TYPICAL USAGE: COMMUTER/ANYROAD

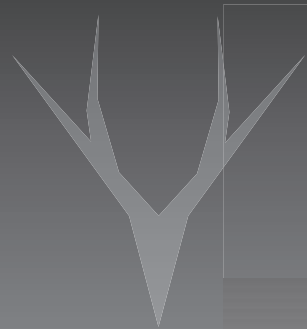

■ Whether you're commuting longer distances, winter training or entering summer sportifs, the Whyte road disk range offers Cyclo Cross durability with pure road geometry. ■ A strong alloy 6061 frame, with mudguard and rack eyelets combined with deep section R-7 wheels and disk brakes will give years of reliable all-season performance. ■ Shimano Sora 9 speed drive train with compact gearing gives a great spread of gear ratios whether commuting fully loaded or winter training.

**Spec highlights:** Pro Max mechanical disk brakes with linear, Kevlar-reinforced full length outer cables / Whyte R-7 deep section rims with 3M reflective decals / Shimano Sora groupset.

## RD7: SUSSEX





# CX : CYCLOCROSS

## CX RACE/ALL TERRAIN

Whyte broke into the CX world with, as you might expect from us, a very eclectic and avant-garde design. Like no other Cyclocross bike in the market we pushed the boundaries of what a CX bike could be, with ride performance and highly evolved Whyte Geometry that gives genuine off-road capability.

For 2014, refinement of an already proven concept has made a good bike even better. Whyte CX Geometry has been tuned further, a completely new chassis has stiffer main tubes for improved tracking and efficiency, while slimmer and curvier seatstays enhances comfort.

The 2014 Whyte CX bikes take our original design concept to an even higher level.







# SAXON CROSS TEAM

TYPICAL USAGE: CYCLOCROSS/ALL TERRAIN



■ The Saxon Cross Team is Whyte's off the shelf CX race bike. Whether round the local park or on the 3 Peaks this bike is all you need. Trail oriented geometry makes this bike exceptionally competent and controllable off-road. ■ SRAM's Force 11 speed group combined with the new RED22 levers give you the world's first fully hydraulic disk road brakes. ■ Easton's straight bladed EA990 XD carbon fork with its tapered steerer tube gives this bike great front end stiffness and steering precision.

**Spec highlights:** Easton EC-90 front fork with full carbon integrated steerer tube / SRAM RED22 hydraulic shifters and brakes / EA90XD wheelset with UST rims.

## CX: SAXON CROSS TEAM



# SAXON CROSS

TYPICAL USAGE: CYCLOCROSS/ALL TERRAIN



■ We have applied our unique Whyte frame geometry to the Saxon Cross, creating Whyte's most versatile all-terrain bike. It's equally at home riding your favourite bridle path, winter training or even commuting. Alternatively, try a CX race this winter - this bike can do it all! ■ SRAM Apex and Rival combine to give a great power delivery and TRP's new HyRd brakes provide the stopping power to give you unrivalled control on any terrain. ■ A straight bladed carbon fork with a tapered steerer tube gives this bike great front end stiffness and steering precision.  
**Spec highlights:** TRP HyRd Hydraulic brakes / WTB TCS (tubeless ready) rims and tyres / PressFit BB-386 crankset, CX gear ratios 46-36.

## CX: SAXON CROSS



WHYTE TEAM  
29" CARBON WHEEL SET



WHYTE R7  
700C WHEEL SET



# WHYTE WHEELS

## PARTS AND ACCESSORIES

Next to the bike frame itself, nothing has a bigger impact on your bike's performance than its wheels. Just as bikes are designed for different environments, wheels also need to be optimised to best suit their intended use. From the highest level XC racing to the daily commute, you can be sure that the Whyte team have chosen the right blend of function and durability. Exclusively designed and tested in the UK, the attention to detail goes as far as having all our wheels hand-trueed to get the ride quality we demand. A hand-trueed wheel can only be as good as the parts it's crafted from. Whyte select only from the best components out there - all alloy wheels use eyelets, brass nipples and either DT Swiss or WTB spokes. However the detail doesn't stop there, we even insist all our spokes use the very best Stainless Steel from Sandvik in Sweden.

### Team Wheels

As the name suggests, these wheels have been developed over several years with and for our Whyte Team athletes and the XC Torq Racing Team. This experience has given us real world race feed-back. In 2013 we launched the XC-209-C wheelset with Whyte's first UD carbon rim, this gave us a very light wheel package which combined with DT Swiss spokes and our own hubs proved to be a winning combination helping both Luke Smith and Neal Crampton to National Titles. We have listened to their invaluable feedback and for 2014 Whyte have improved this wheelset by adding a 23mm wide Tubeless ready rim and added the all new XC-209-C Team wheelset. The new Team wheels feature the same 23mm wide rim with an alloy freehub body with straight pull hubs and spokes, reducing the weight to a sub 1650g package.

### Alloy XC Wheels

Further down the line you'll find our Alloy XC-209 wheelset. These hand built wheels use a fusion welded rim to give the best trueness and balance as well as brass nipples and high performance spokes.

### R7 700c Wheels

The technology and attention to detail in our wheels is not just reserved for the XC bikes in our line - the R7 Commuter and RD7 Road Disk bikes also get the same design care. Commuter and training bikes are your "work horse" so you expect exceptional durability. Whyte use eyelets on all our deep section rims, as well as brass nipples and a 32 spoke, 3 cross pattern rear lacing for exceptional strength.



So whether you are riding some rough cross country terrain or zipping in and out of the commuter traffic you can be sure the Whyte team have tried and tested your wheels to ensure maximum stability, reliability and strength. Remember, it's not just about the bike.





# WHYTE

## PARTS AND ACCESSORIES



Upgrade your bike with Whyte Parts and Accessories.

Whyte have carefully selected parts and accessories that we are confident will improve your riding experience, offering performance, quality and dare we say it, style. Manufactured by leaders in their field, you can be sure any part that carries the Whyte brand logo has been tried and tested and offers best of breed performance.

For a full list of Whyte parts and accessories please visit: [whytebikes.co.uk](http://whytebikes.co.uk)

# WHYTE FRAME GEOMETRY

Geometry, the angles that define the way a bike interacts with the rider and the trail, is the most important part of any bike's character and performance. It affects every aspect from that welcoming initial confidence, comfort and control, to how hard you push yourself hours into a race or what new technical sections you've mastered months after your first ride. Whether it's that crucial traction balance on the crux move of a killer climb or calmly making a turn millimeters from the edge of potential disaster on a flat out descent, we've designed our bikes to handle superbly in every situation.

Our R&D office uses Autodesk 3D CAD packages to allow us to conceive, develop and perfect potential geometry before we even get on the trail.

Unlike many manufacturers we rework our geometry for each and every bike too.

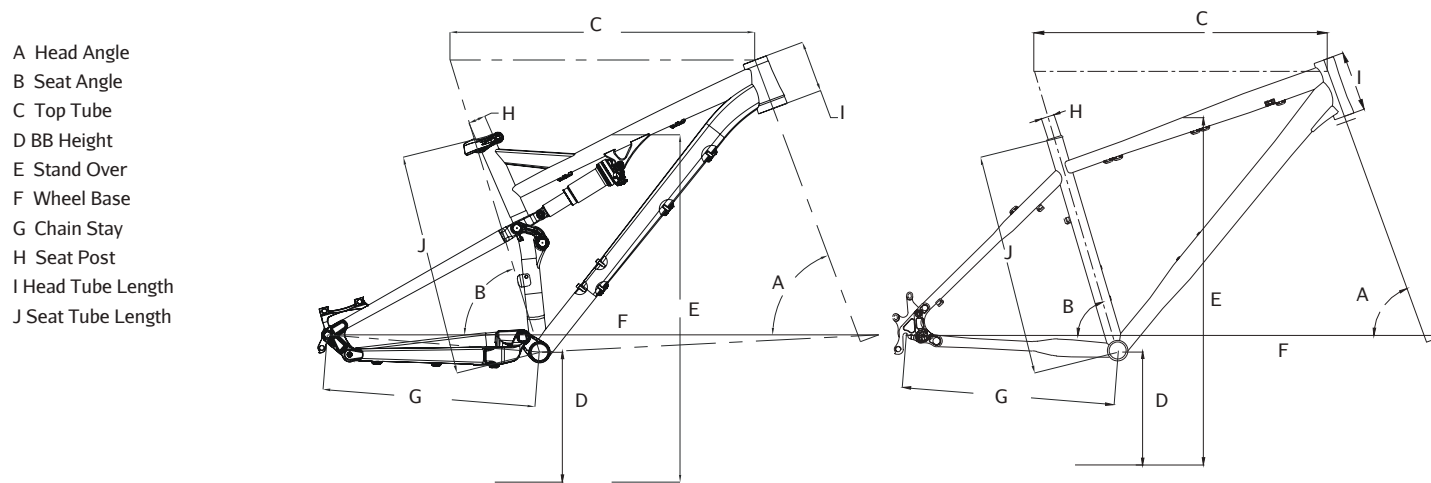

Likely use, likely riders, suspension function, frame attributes it all affects what angles and dimension will create the optimum character. We also break down each individual aspect of a bike's geometry as well as the components we use so we can isolate and precision tune each vital variable. By co-developing suspension and handling geometry in tandem we can ensure that both work together seamlessly in every situation too.

Finally we build a selection of prototypes for our development team to appraise, prove and perfect in real world trail conditions that no computer simulation can hope to match. It's the feedback of these brutally uncompromising riders as well as our sponsored athletes that give the stamp of true trail authority or send us back to the drawing board again.



T-129 Works   T-129 S   T-129										
Frame Size	A	B	C	D	E	F	G	H	I	J
S	68.0°	74.3°	576mm	343mm	805mm	1125mm	431mm	30.9mm	100mm	432mm
M	68.0°	74.0°	596mm	343mm	808mm	1145mm	431mm	30.9mm	100mm	445mm
L	68.0°	73.8°	610mm	343mm	813mm	1160mm	431mm	30.9mm	110mm	483mm
M-109 C Team   M-109 S   M-109										
Frame Size	A	B	C	D	E	F	G	H	I	J
S	69.5°	74.2°	579mm	335mm	795mm	675mm	431mm	30.9mm	105mm	432mm
M	69.5°	74.0°	599mm	335mm	797mm	695mm	431mm	30.9mm	105mm	445mm
L	69.5°	73.8°	614mm	335mm	801mm	710mm	431mm	30.9mm	115mm	483mm
XL	69.5°	73.7°	629mm	335mm	805mm	725mm	431mm	30.9mm	120mm	521mm
G-150 Works   G-150										
Frame Size	A	B	C	D	E	F	G	H	I	J
S	67.0°	74.2°	599mm	343mm	815mm	1154mm	425mm	30.9mm	95mm	432mm
M	67.0°	74.0°	613mm	343mm	816mm	1169mm	425mm	30.9mm	110mm	445mm
L	67.0°	73.8°	633mm	343mm	820mm	1189mm	425mm	30.9mm	120mm	483mm
909										
Frame Size	A	B	C	D	E	F	G	H	I	J
S	66.2° - 66.8°	72.7° - 73.3°	599mm	305mm	785mm + / - 3	1109- 1129mm	415-435mm	30.9mm	110mm	406mm
M	66.2° - 66.8°	72.7° - 73.3°	618mm	305mm	801mm + / - 3	1129- 1149mm	415-435mm	30.9mm	120mm	455mm
L	66.2° - 66.8°	72.7° - 73.3°	635mm	305mm	830mm + / - 3	1149- 1169mm	415-435mm	30.9mm	140mm	491mm
905   901										
Frame Size	A	B	C	D	E	F	G	H	I	J
S	66.5°	73.0°	599mm	305mm	777mm	1119mm	425mm	30.9mm	110mm	406mm
M	66.5°	73.0°	618mm	305mm	805mm	1139mm	425mm	30.9mm	120mm	455mm
L	66.5°	73.0°	635mm	305mm	832mm	1169mm	425mm	30.9mm	140mm	491mm
XL	66.5°	73.0°	654mm	305mm	861mm	1189mm	430mm	30.9mm	150mm	533mm
806 650b/27.5 Women's   802 650b/27.5 Women's										
Frame Size	A	B	C	D	E	F	G	H	I	J
XS	68.5°	74.0°	571mm	304mm	776mm	1089mm	435mm	30.9mm	107mm	381mm
S	68.5°	73.5°	586mm	304mm	784mm	1099mm	435mm	30.9mm	115mm	406mm
M	68.5°	73.5°	600mm	304mm	804mm	1114mm	435mm	30.9mm	125mm	445mm

Geometry details were correct at the time of printing. However, product changes may occur after this time. Please check model availability and full geometry details with your dealer prior to ordering.

805 650b/27.5   801 650b/27.5										
Frame Size	A	B	C	D	E	F	G	H	I	J
S	68.5°	73.5°	594mm	304mm	779mm	1107mm	435mm	30.9mm	115mm	406mm
M	68.5°	73.5°	608mm	304mm	797mm	1123mm	435mm	30.9mm	125mm	445mm
L	68.5°	73.0°	628mm	304mm	822mm	1137mm	435mm	30.9mm	135mm	483mm
XL	68.5°	73.0°	639mm	304mm	851mm	1149mm	435mm	30.9mm	145mm	533mm
X-401 26er Kids										
Frame Size	A	B	C	D	E	F	G	H	I	J
13"	68.5°	74.0°	563mm	305mm	714mm	1076mm	425mm	30.9mm	100mm	331mm
29-C Team   29-C S   29-C										
Frame Size	A	B	C	D	E	F	G	H	I	J
S	69.3°	72.8°	612mm	304mm	789mm	1117mm	438mm	30.9mm	100mm	432mm
M	69.3°	72.8°	627mm	304mm	809mm	1128mm	438mm	30.9mm	110mm	470mm
L	69.3°	72.8°	641mm	304mm	844mm	1145mm	438mm	30.9mm	120mm	521mm
729   629   529										
Frame Size	A	B	C	D	E	F	G	H	I	J
S	68.5°	73.0°	600mm	305mm	805mm	1113mm	440mm	30.9mm	110mm	432mm
M	68.5°	73.0°	615mm	305mm	820mm	1128mm	440mm	30.9mm	115mm	470mm
L	68.5°	73.0°	629mm	305mm	832mm	1143mm	440mm	30.9mm	120mm	521mm
Strawberry Hill Ladies										
Frame Size	A	B	C	D	E	F	G	H	I	J
S	68.0°	74.5°	537mm	283mm	685mm	1056mm	435mm	30.9mm	130mm	432mm
M	69.0°	74.0°	563mm	283mm	681mm	1070mm	435mm	30.9mm	160mm	457mm
L	69.0°	73.5°	587mm	283mm	672mm	1090mm	435mm	30.9mm	180mm	495mm
Caledonian Ladies   Malvern Ladies										
Frame Size	A	B	C	D	E	F	G	H	I	J
S	68.0°	74.5°	557mm	288mm	728mm	1073mm	435mm	30.9mm	107mm	432mm
M	69.0°	74.0°	584mm	288mm	747mm	1085mm	435mm	30.9mm	115mm	457mm
L	69.0°	73.5°	609mm	288mm	767mm	1105mm	435mm	30.9mm	125mm	495mm
Chiltern   Caledonian   Malvern										
Frame Size	A	B	C	D	E	F	G	H	I	J
S	69.0°	74.0°	589mm	288mm	784mm	1101mm	435mm	30.9mm	115mm	457mm
M	69.0°	73.5°	614mm	288mm	815mm	1121mm	435mm	30.9mm	125mm	495mm
L	69.0°	73.0°	629mm	288mm	842mm	1131mm	435mm	30.9mm	135mm	546mm
XL	69.0°	73.0°	644mm	288mm	864mm	1146mm	435mm	30.9mm	145mm	585mm



Pimlico Women's   Victoria Women's										
Frame Size	A	B	C	D	E	F	G	H	I	J
S	69.0°	74.5°	549mm	272mm	708mm	1040mm	420mm	27.2mm	115mm	394mm
M	69.5°	73.5°	574mm	272mm	738mm	1052mm	420mm	27.2mm	135mm	432mm
L	70.0°	73.0°	600mm	272mm	763mm	1069mm	420mm	27.2mm	155mm	470mm
Montpellier										
Frame Size	A	B	C	D	E	F	G	H	I	J
M	70.0°	73.5°	597mm	272mm	744mm	1069mm	420mm	27.2mm	140mm	445mm
L	70.0°	73.0°	616mm	272mm	776mm	1084mm	420mm	27.2mm	160mm	495mm
XL	70.0°	73.0°	623mm	272mm	804mm	1099mm	420mm	27.2mm	180mm	533mm
Stirling   Cambridge   Portobello										
Frame Size	A	B	C	D	E	F	G	H	I	J
S	69.5°	74.0°	570mm	272mm	723mm	1052mm	420mm	27.2mm	120mm	406mm
M	70.0°	73.5°	595mm	272mm	743mm	1069mm	420mm	27.2mm	140mm	445mm
L	70.0°	73.0°	614mm	272mm	779mm	1084mm	420mm	27.2mm	160mm	495mm
XL	70.0°	73.0°	628mm	272mm	805mm	1099mm	420mm	27.2mm	180mm	533mm
Suffolk   Dorset   Sussex										
Frame Size	A	B	C	D	E	F	G	H	I	J
50cm	72.0°	74.5°	525mm	279mm	771mm	993mm	425mm	27.2mm	130mm	500mm
52cm	72.5°	74.0°	540mm	279mm	789mm	998mm	425mm	27.2mm	145mm	520mm
54cm	73.0°	73.5°	555mm	279mm	806mm	1003mm	425mm	27.2mm	160mm	540mm
56cm	73.0°	73.0°	570mm	279mm	822mm	1013mm	425mm	27.2mm	175mm	560mm
58cm	73.0°	73.0°	585mm	279mm	838mm	1028mm	425mm	27.2mm	190mm	580mm
Saxon Cross Team   Saxon Cross										
Frame Size	A	B	C	D	E	F	G	H	I	J
52cm	70.0°	74.0°	560mm	279mm	799mm	1050mm	430mm	27.2mm	145mm	520mm
54cm	70.0°	73.5°	575mm	279mm	813mm	1060mm	430mm	27.2mm	160mm	540mm
56cm	70.0°	73.0°	589mm	279mm	829mm	1075mm	435mm	27.2mm	175mm	560mm
58cm	69.3°	73.0°	598mm	279mm	844mm	1085mm	435mm	27.2mm	190mm	580mm

Geometry details were correct at the time of printing. However, product changes may occur after this time. Please check model availability and full geometry details with your dealer prior to ordering.

	TRAIL SUSPENSION			XC MARATHON
Model	T-129 Works	T-129 S	T-129	M-109 C Team
Colour	Matt Zinc/Aqua	Matt Zinc/Aqua	Matt Zinc/Lime	Matt UD Carbon FT, Matt Granite RT/Aqua
Sizes Available	S, M, L	S, M, L	S, M, L	M, L
Frame	6061 T6 Aluminium Front Triangle with Tapered Head Tube and alloy rear Triangle with 142 dropouts	6061 T6 Aluminium Front Triangle with Tapered Head Tube and alloy rear Triangle with 142 dropouts	6061 T6 Aluminium Front Triangle with Tapered Head Tube and alloy rear Triangle with 142 dropouts	High-Modulus UD Carbon Front Triangle with Tapered Head Tube and alloy rear Triangle with E-Thru dropouts
Fork	Fox Float 32 Performance 29" with CTD FIT, 120mm Travel, Tapered steerer and 15QR	RockShox Reba 29", RL, 120mm Travel, Tapered steerer and 15mm Maxle	RockShox Reba 29", RL, 120mm Travel, Tapered steerer and 15mm Maxle	Fox Float 32 Factory 29" with CTD Adjust, FIT, 100mm Travel, Tapered steerer and 15QR
Rear Shock	Float Performance with Boost Valve, Rebound Adjustment and CTD Adjust	RockShox Monarch, RT3, Adjustable Rebound and Compression	RockShox Monarch, RL, with Adjustable Rebound and Compression	Float Factory with Boost Valve, Rebound Adjustment and CTD Adjust
Headset	FSA Orbit ZS, 1.5" Cartridge Sealed Lower Bearing Lower and 1 1.8" Upper Bearing	FSA Orbit ZS, 1.5" Cartridge Sealed Lower Bearing Lower and 1 1.8" Upper Bearing	FSA Orbit ZS, 1.5" Cartridge Sealed Lower Bearing Lower and 1 1.8" Upper Bearing	FSA Integrated Road, 1 1/8" upper Sealed Cartridge Bearing, 1.5 lower Sealed Cartridge Bearing
Rear Hub	Hope EVO Disc, 10 Speed, 32 Hole, 12 X 142mm	Alloy, Double Sealed Cartridge Bearing Hub 12mm X 142mm Through Axle, 32 Hole	Alloy, Double Sealed Bearing Hub 12mm X 142mm Through Axle, 32 Hole	Whyte XC-209-C Team Carbon Wheelset, 28 Straight Pull SiSt spokes, 12mm E Thru, Alloy Freehub, 6 Bolt hub with double sealed cartridge bearings
Front Hub	Alloy, Double Sealed Cartridge Bearing Hub 15mm Through Axle, 32 Hole	Alloy, Double Sealed Cartridge Bearing Hub 15mm, 32 Hole	Alloy, Double Sealed Bearing Hub 15mm Through Axle, 32 Hole	Whyte XC-209-C Team Wheelset, 28 Straight Pull SiSt flat spokes, QR15, 6 Bolt hub with double sealed cartridge bearings
Spokes	WTB Double Butted, Black Sandvik Stainless Steel Spokes, Brass Nipples	WTB Double Butted, Black Sandvik Stainless Steel Spokes, Brass Nipples	WTB Double Butted, Black Sandvik Stainless Steel Spokes, Brass Nipples	Black Stainless Steel Spokes, DT Swiss Prolock Alloy Nipples
Rims	WTB STI19 29" Rims with TCS System, Tubeless Ready	WTB STI19 29" Rims with TCS System, Tubeless Ready	Whyte Trail 22 Disc Rims, 32 Hole	Whyte X-C-209-C Team Uni-Directional High-Modulus Carbon, 23mm wide, Tubeless Ready
Tyres	WTB Bronson, 29" X 2.2" TCS Race DNA Folding Bead, WTB Nano, 29" X 2.2" TCS Race DNA Folding Bead Rear	WTB Bronson, 29" X 2.2" TCS Race DNA Folding Bead, WTB Nano, 29" X 2.2" TCS Race DNA Folding Bead Rear	Maxxis Ardent, 29" X 2.25" Folding Front, Maxxis IKON, 29" X 2.2" Folding Rear	Maxxis IKON, 120TPI, 29" X 2.2" Folding
Shift Levers	Shimano XT, I-Spec, 10 Speed	SRAM X-9 Matchmaker, 10 Speed	SRAM X-7, 10 Speed	Shimano XTR I-Spec, 10 Speed
Front Derailleur	Shimano SLX, High Direct Mount, 10 Speed	SRAM X-7, High Direct Mount, 10 Speed	SRAM X-7, High Direct Mount, 10 Speed	Shimano XTR, High Direct Mount, 10 Speed
Rear Derailleur	Shimano XT Shadow Plus, 10 Speed, Black	SRAM X-9, Type 2, 10 Speed	SRAM X-7, Type 2, 10 Speed, Custom Green	Shimano XTR, Shadow Plus, 10 Speed
Cassette	Shimano HG81 11-36, 10 Speed	SRAM PG-1050 11-36, 10 Speed	SRAM PG-1030 11-36, 10 Speed	Shimano HG771-10 11-36, 10 Speed
Chain	Shimano HG54, 10 Speed	SRAM PC-1031, 10 Speed	SRAM PC-1031, 10 Speed	Shimano HG54, 10 Speed
Crankset	Shimano XT, 38-24 29er Ratio, Compact Double, 10 Speed, Black	SRAM S1400 GXP, 36-22 29er Trail Ratio, Compact Double, 10 Speed	SRAM S1000 GXP, 36-22 29er Trail Ratio, Compact Double, 10 Speed	Shimano XT, Hollow Tech II, 40-30-22, 10 Speed 29er specific Ratios
Bottom Bracket	Shimano Hollow Tech II	SRAM GXP	SRAM GXP	Shimano Hollow Tech II
Seatpost	RockShox Reverb Stealth, 30.9 X 380mm	RockShox Reverb Stealth, Matchmaker, 30.9 X 380mm	Whyte Alloy 2014, 30.9mm x 410mm, 2 Bolt Clamp	FSA SL-K, 30.9mm x 410mm, Zero Offset, 2 Bolt Clamp
Seat	Fi'zi:k Gobi XM, Mag Rails	Whyte Custom dual density, triple panel design	Whyte Custom dual density, triple panel design	Fi'zi:k Custom Tundra II
Bar	Whyte Custom 2014 Alloy, 15mm Rise, 750mm Wide	Whyte Custom 2014 Alloy, 15mm Rise, 750mm Wide	Whyte Custom 6061 Alloy, 20mm Rise, 750mm Wide	FSA SL-K Flat Bar 700mm Wide
Stem	Whyte Gravity Stem, 60mm S, 70mm M, 80mm L	Whyte Trail Stem, 60mm S, 70mm M, 80mm L	Whyte Trail Stem, 60mm S, 70mm M, 80mm L	Whyte Custom, -6 Degree, 80mm M, 90mm L
Grips	Whyte Lock-on	Whyte Lock-on	Whyte Lock-on	Whyte Lock-on, EVA Light-weight Foam
Front Brake	Shimano XT, 180mm Rotor	Avid Elixir 5, 180mm Rotor	Avid Elixir 3, 180mm Rotor	Shimano XTR, 180mm Ice Tech Rotor with metal pads and Cooling Fin's
Rear Brake	Shimano XT, 160mm Rotor	Avid Elixir 5, 160mm Rotor	Avid Elixir 3, 160mm Rotor	Shimano XTR, 160mm Ice Tech Rotor with metal pads and Cooling Fin's
Brake Levers	Shimano XT I-Spec	Avid Elixir 5 Matchmaker	Avid Elixir 3	Shimano XTR I-Spec
Pedals	None	None	None	None



	XC MARATHON		GRAVITY ENDURO SUSPENSION	
Model	M-109 S	M-109	G-150 Works	G-150
Colour	Matt Granite FT, Matt White RT/Aqua	Matt Granite FT, Matt White RT/Apple	Matt Zinc/Aqua	Matt Zinc/Burnt Orange
Sizes Available	S, M, L, XL	S, M, L, XL	S, M, L	S, M, L
Frame	6061 T6 Aluminium Front Triangle with Tapered Head Tube and alloy rear Triangle with E-Thru dropouts	6061 T6 Aluminium Front Triangle with Tapered Head Tube and alloy rear Triangle with E-Thru dropouts	6061 T6 Aluminium Front Triangle with Tapered Head Tube and alloy rear Triangle with 142 dropouts	6061 T6 Aluminium Front Triangle with Tapered Head Tube and alloy rear Triangle with 142 dropouts
Fork	Fox Float 32 Performance 29" with CTD FIT, 100mm Travel, Tapered steerer and 15QR	Fox Float 32 Evolution 29", 100mm Travel, Tapered steerer and 15QR	Fox Float 34 Factory Kashima, 27.5" with CTD Adjust, FIT, 150mm Travel, Tapered steerer and 15QR	RockShox Pike 27.5", RC, 150mm Travel, Tapered steerer and 15mm Maxle
Rear Shock	Float Performance with Boost Valve, Rebound Adjustment and CTD Adjust	Float Performance with Boost Valve, Rebound Adjustment and CTD Adjust	Float Float X, Kashima with CTD Adjust and Rebound Adjustment	RockShox Monarch, RT3, Adjustable Rebound and Compression
Headset	FSA Orbit ZS, 1.5" Cartridge Sealed Lower Bearing Lower and Cartridge Bearing 1 1.8" Upper Bearing	FSA Orbit ZS, 1.5" Cartridge Sealed Lower Bearing Lower and 1 1.8" Upper Bearing	FSA Orbit ZS, 1.5" Cartridge Sealed Lower Bearing Lower and Cartridge Bearing 1 1.8" Upper Bearing	FSA Orbit ZS, 1.5" Cartridge Sealed Lower Bearing Lower and Cartridge Bearing 1 1.8" Upper Bearing
Rear Hub	Whyte XC-209-C Carbon Wheelset, 32 StSt spokes, 12mm E Thru, 6 Bolt hub with double sealed cartridge bearings	Whyte XC-209 Wheelset, 32 StSt flat spokes, 12mm E Tru, 6 Bolt hub with double sealed cartridge bearings	SRAM Rail, 23mm wide 27.5", Full UST Wheelset	Alloy, Double Sealed Cartridge Bearing Hub 12mm X 142mm Through Axle, 32 Hole
Front Hub	Whyte XC-209-C Carbon Wheelset, 28 StSt spokes, QR 15, 6 Bolt hub with double sealed cartridge bearings	Whyte XC-209 Wheelset, 28 StSt flat spokes, QR15, 6 Bolt hub with double sealed cartridge bearings	SRAM Rail, 23mm wide 27.5", Full UST Wheelset	Alloy, Double Sealed Cartridge Bearing Hub 15mm, 32 Hole
Spokes	Triple Butted Stainless Steel	Black Stainless Steel Spokes	SRAM Rail, 23mm wide 27.5", Full UST Wheelset	WTB Double Butted, Black Sandvik Stainless Steel Spokes
Rims	Whyte X-C-209-C Uni-Directional High-Modulus Carbon, 23mm wide, Tubeless Ready	Whyte XC-209, welded joint	SRAM Rail, 23mm wide 27.5", Full UST Wheelset	WTB STI23 650b Rims with TCS System, Tubeless Ready
Tyres	Maxxis IKON, 120TPI, 29" X 2.2" Folding	Maxxis IKON, 120TPI, 29" X 2.2" Folding	Maxxis Ardent, 27.5" X 2.25" 60TPI Folding Bead, Maxxis Crossmark, 27.5" X 2.1" 60TPI Folding Bead Rear	WTB Wolverine TCS Race, 650b X 2.2" Folding Front, WTB Wolverine TCS Race with Inner Peace Sidewall Protection, 27.5" X 2.2"
Shift Levers	Shimano XT I-Spec, 10 Speed	Shimano Deore I-Spec, 10 Speed	SRAM X01, Matchmaker, 11 Speed	SRAM X-9, Matchmaker, 10 Speed
Front Derailleur	Shimano XT, High Direct Mount, 10 Speed	Shimano Deore, High Direct Mount, 10 Speed	N/A	SRAM X-7, High Direct Mount, 10 Speed
Rear Derailleur	Shimano XT, Shadow Plus, 10 Speed	Shimano SLX, Shadow Plus, 10 Speed	SRAM X01, Type 2, 11 Speed	SRAM X-9, Type 2, 10 Speed
Cassette	Shimano HG81-10 11-36, 10 Speed	Shimano HG62-10 11-36, 10 Speed	SRAM XG1195 10-42, 11 Speed	SRAM PG-1050 11-36, 10 Speed
Chain	Shimano HG54, 10 Speed	Shimano HG54, 10 Speed	SRAM PCXX1, 11 Speed	SRAM PC-1031, 10 Speed
Crankset	Shimano XT, Hollow Tech II, 40-30-22, 10 Speed 29er specific Ratios	Shimano SLX, Hollow Tech II, 40-30-22, 10 Speed 29er specific Ratios	SRAM X01 32T, 11 Speed with Chain Guard	SRAM S1400 GXP, 36-22 Gravity Ratio Compact Double, 10 Speed
Bottom Bracket	Shimano Hollow Tech II	Shimano Hollow Tech II	SRAM GXP	SRAM GXP
Seatpost	Whyte Alloy 2014, 30.9mm x 410mm, Zero Offset, 2 Bolt Clamp	Whyte Alloy 2014, 30.9mm x 410mm Zero Offset, 2 Bolt Clamp	RockShox Reverb Stealth Matchmaker, 30.9 X 380mm	RockShox Reverb Stealth, MatchMaker, 30.9 X 355mm
Seat	Whyte Custom dual density, triple panel design	Whyte Custom dual density, triple panel design	Fi'zi:k Gobi XM, Matt/Gloss	Whyte Custom dual density, triple panel design
Bar	Whyte Custom 2014 Alloy, Flat, 730mm Wide	Whyte Custom 6061 Alloy, Flat, 700mm Wide	Easton Havoc 35mm Oversize, 800mm wide	Whyte Custom 2014 Alloy, 15mm Rise, 750mm Wide
Stem	Whyte Custom, -6 Degree, 70mm S, 80mm M, 90mm L & XL	Whyte Custom, -6 Degree, 70mm S, 80mm M, 90mm L	Easton Havoc, 35mm Oversize, 50mm long	Whyte Gravity Stem, 50mm S, 50mm M, 60mm L
Grips	Whyte Lock-on, EVA Light-weight Foam	Whyte Lock-on	Whyte Lock-on	Whyte Lock-on
Front Brake	Shimano XT BR785, 180mm Rotor	Shimano BR596, 180mm XT Rotor	Avid X0 Trail 4 Pots, 180mm Rotor	Avid Elixir 7 Trail, 4 Pots, 180mm Rotor
Rear Brake	Shimano XT BR785, 160mm Rotor	Shimano BR596, 160mm Rotor	Avid X0 Trail 4 Pots, 180mm Rotor	Avid Elixir 7 Trail, 4 Pots, 180mm Rotor
Brake Levers	Shimano XT BR785 I-Spec	Shimano BR596, I-Spec	Avid X0 Trail Matchmaker	Avid Elixir 7 Trail, Matchmaker
Pedals	None	None	None	None

Specification details were correct at the time of printing. However, product changes may occur after this time. Please check model availability and full specification details with your dealer prior to ordering.

	TRAIL HT			XC HT
Model	909	905	901	806 650b/27.5 Women's
Colour	Matt Zinc/Grey	Matt Zinc/Aqua	Matt Zinc/Lime	Matt White/Plum
Sizes Available	S, M, L	S, M, L, XL	S, M, L, XL	XS, S, M
Frame	6061 Hydro Formed T6 Aluminium, Custom Drawn and Multi Butted, Tapered Headtube and Whyte's adjustable dropout system	6061 Hydro Formed T6 Aluminium, Custom Drawn and Multi Butted, Tapered Headtube	6061 Hydro Formed T6 Aluminium, Custom Drawn and Multi Butted, Tapered Headtube	6061 Hydro Formed T6 Aluminium, Custom Drawn and Multi Butted
Fork	Fox 32 Performance, CTD FIT, 27.5" 130mm Travel, Tapered Steerer and 15QR	RockShox Revelation RL, 27.5" Lock-out, Maxle Light 130mm Travel, Solo Air, Adjustable Compression and Rebound, Tapered Steerer	RockShox Sektor Gold 27.5" Lock-out, Maxle Light 130mm Travel, Solo Air, Adjustable Compression and Rebound, Tapered Steerer	RockShox XC 30, 100mm Travel, Adjustable Rebound, Turn Key Lockout
Headset	FSA Orbit ZS, Sealed Cartridge Bearings, 1.5" Lower, 1 1.8" Upper Bearings	FSA Orbit ZS, Sealed Cartridge Bearings, 1.5" Lower, 1 1.8" Upper Bearings	FSA Orbit ZS, Sealed Cartridge Bearing 1.5" Lower, 1 1.8" Caged Upper Bearings	FSA No. 10 Caged Bearings
Rear Hub	Hope EVO Disc, 11 Speed, 32 Hole, 135mm, Shimano XT QR	Hope EVO Disc, 32 Hole, 135mm, Shimano XT QR	Alloy, Double Sealed, 32 Hole	Alloy, Double Sealed, 28 Hole
Front Hub	Alloy, Double Sealed Cartridge Bearing Hub 15mm, 32 Hole	Alloy, Double Sealed Bearing Hub 15mm, 32 Hole	Alloy, Double Sealed Bearing Hub 15mm Through Axle, 32 Hole	Alloy, Double Sealed, 32 Hole
Spokes	WTB 15 gauge Black Sandvik Stainless with Brass Nipples	DT Champion 1.8mm Black Stainless with Brass Nipples	WTB 15 gauge Black Sandvik Stainless with Brass Nipples	WTB 15g, Black Stainless with Brass Nipples
Rims	WTB STI 19 TCS 650b Tubeless ready rims, 32 Hole	Whyte Trail 22 Disc Rims, 32 Hole	Whyte Trail 21 Disc rim, 32 Hole	WTB STI19 650b Rims with TCS System, Tubeless Ready, 28 Hole Front, 32 Hole Rear
Tyres	WTB Wolverine 650b x 2.25", 60TPI Dual Compound, Folding Bead Front, WTB Beeline TCS 27.5" x 2.25", 60TPI Dual Compound, Folding Bead, Rear	Maxxis Ardent, 27.5" X 2.25" 60TPI Folding Bead, Maxxis Crossmark, 27.5" X 2.1" 60TPI Folding Bead Rear	Maxxis Ardent, 27.5" X 2.25" 60TPI Folding Bead, Maxxis Crossmark, 27.5" X 2.1" 60TPI Folding Bead Rear	WTB BeeLine TCS Folding 650b x 2.2"
Shift Levers	SRAM X01, 11 Speed	Shimano Deore, 10 Speed, I-Spec	SRAM X-5, 10 Speed	Shimano Deore, 10 Speed
Front Derailleur	N/A	Shimano Deore, 10 Speed	SRAM X-5, 10 Speed	Shimano Deore, 10 Speed
Rear Derailleur	SRAM X01, Type 2 medium cage, 11 Speed	Shimano SLX, Shadow Plus, 10 Speed	SRAM X-7 Type 2 Medium Cage, 10 Speed, Custom Green	Shimano SLX RD-M670 Shadow
Cassette	SRAM XG-1195, 10-42, 11 Speed	Shimano HG-81 SLX, 11-36, 10 Speed	SRAM PG-1030, 11-36, 10 Speed	Shimano HG-62, 11-36, 10 Speed
Chain	SRAM PCXX1, 11 Speed	Shimano HG54, 10 Speed	SRAM PC-1031, 10 Speed	FSA Team Issue, 10 Speed
Crankset	SRAM X01, GXP, 32T, 11 Speed with Chain Guard	Race Face Ride, 38-24, 10 Speed, Compact Double	SRAM FC S1000, GXP, 38-24, 10 Speed, Double Compact	Shimano M522, 42-32-22, Silver, 10 Speed with 170mm Cranks
Bottom Bracket	SRAM GXP	Race Face	SRAM GXP	Shimano Hollow Tech II
Seatpost	Whyte 20mm Offset, 30.9mm x 400mm, 2014 Alloy, 2 Bolt Clamp	Whyte 20mm Offset, 30.9mm x 400mm, 2014 Alloy, 2 Bolt Clamp	Whyte 20mm Offset, 30.9mm x 400mm, 6061 Alloy, 2 Bolt Clamp	Whyte 20mm Offset, 30.9mm x 400mm, 6061 Alloy, 2 Bolt Clamp
Seat	Fizik Gobi XM, Mag Rails	Whyte Custom, Triple Panel Design	Whyte Custom, Triple Panel Design	Whyte Custom Women's fit
Bar	Whyte Custom 2014 Alloy, Low Rise, 750mm Wide	Whyte Custom 2014 Alloy, Low Rise, 750mm Wide	Whyte Custom 6061 Alloy, Low Rise, 750mm Wide	Whyte Riser Bar 30mm rise, 31.8mm, 680mm Wide
Stem	Whyte Gravity Stem, 60mm S, 60mm M, 70mm L	Whyte Gravity Stem, 60mm S, 60mm M, 70mm L, 80mm XL	Whyte Gravity Stem, 60mm S, 60mm M, 70mm L, 80mm XL	Whyte Custom, 70mm S, 70mm M, 90mm L & XL
Grips	Whyte Custom Lock-on	Whyte Custom Lock-on	Whyte Custom Lock-on	Whyte Custom Lock-on
Front Brake	Shimano XT, 180mm Rotor	Shimano BR-615, 180mm Rotor	Avid Elixir 3, 180mm Rotor	Tektro HDC 330, 160mm rotor
Rear Brake	Shimano XT, 160mm Rotor	Shimano BR-615, 160mm Rotor	Avid Elixir 3, 160mm Rotor	Tektro HDC 330, 160mm rotor
Brake Levers	Shimano	Shimano BL-615, Matchmaker	Avid Elixir 3	Tektro HDC 330 WDS
Pedals	None	None	None	VP Composite with Alloy Cage and Toe Clip



	XC HT			
Model	805 650b/27.5	802 650b/27.5 Women's	801 650b/27.5	X-401 26er Youth
Colour	Matt White/Apple	Matt White/Aqua	Matt Granite/Aqua	Matt White/Aqua
Sizes Available	S, M, L, XL	XS, S, M	S, M, L, XL	13"
Frame	6061 Hydro Formed T6 Aluminium, Custom Drawn, Multi Butted with Post Mount Dropouts	6061 Hydro Formed T6 Aluminium, Custom Drawn and Multi Butted	6061 Hydro Formed T6 Aluminium, Custom Drawn, Multi Butted with Post Mount Dropouts	6061 Hydro Formed T6 Aluminium, Custom Drawn and Multi Butted
Fork	RockShox XC-30 Gold, 100mm Travel, Adjustable Rebound, Tapered Alloy Steerer, Turn Key Lockout	SR XCR, 100mm Travel, Alloy Steerer, Adjustable Rebound, Hydro Lockout	SR XCR, 100mm Travel, Alloy Steerer, Adjustable Rebound, Hydro Lockout	SR Raidon, 100mm Travel, Alloy Stanchions, Alloy Steerer, Adjustable Rebound, Hydro Lockout
Headset	FSA No. 10 Caged Bearings	FSA No. 10 Caged Bearings	FSA No. 10 Caged Bearings	FSA No. 10 Caged Bearings
Rear Hub	Alloy, Double Sealed Bearing Hub, 32 Hole, Green Anodize	Alloy, Double Sealed Bearing Hub, 32 Hole	Alloy, Double Sealed Bearing Hub, 32 Hole	Alloy, Double Sealed Bearing Hub, 28 Hole
Front Hub	Alloy, Double Sealed Bearing Hub, 32 Hole, Green Anodize	Alloy, Double Sealed Bearing Hub, 32 Hole	Alloy, Double Sealed Bearing Hub, 32 Hole	Alloy, Double Sealed Bearing Hub, 28 Hole
Spokes	WTB 15g, Black Stainless with Brass Nipples	WTB 15g, Black Stainless with Brass Nipples	WTB 15g, Black Stainless with Brass Nipples	WTB 15g, Black Stainless with Brass Nipples
Rims	Whyte XC-22, sleeve joint rim, 32 Hole	Whyte XC-20, 32 Hole	Whyte XC-20, 32 Hole	Whyte XC-20, 28 Hole
Tyres	Maxxis IKON, Wire 27.5" x 2.2"	Maxxis IKON Wire 27.5" x 2.2"	Maxxis IKON Wire 27.5" x 2.2"	Continental X-King Folding 26" x 2.2"
Shift Levers	SRAM X-5, 10 Speed	Shimano Acera, 9 Speed	Shimano Acera, 9 Speed	SRAM X0 GripShift, 10 Speed
Front Derailleur	SRAM X-5, 10 Speed	Shimano Altus, 9 Speed	Shimano Altus, 9 Speed	N/A
Rear Derailleur	SRAM X-7, Long Cage, 10 Speed	Shimano Deore RD-M592 Shadow	Shimano Deore RD-M592 Shadow	SRAM X-7, Type 2, 10 Speed
Cassette	SRAM PG-1030 11-36, 10 Speed	Shimano HG-20, 11-34, 9 Speed	Shimano HG-20, 11-34, 9 Speed	SRAM 1030, 11-36, 10 Speed
Chain	SRAM PC 1031, 10 Speed	KMC X9, 9 Speed	KMC X9, 9 Speed	SRAM PC3031, 10 Speed
Crankset	SRAM FC800, 44-32-22 with Power Spline, 10 Speed	Shimano M391, 44-32-22, Silver, 9 Speed with 170mm Cranks, Octalink	Shimano M391, 44-32-22, 9 Speed, Octalink	SRAM Firex GXP, T33 Single With Chain Guard, 170mm Crank, 10 Speed
Bottom Bracket	SRAM Power Spline	Shimano BB-ES25 Octalink	Shimano BB-ES25 Octalink	SRAM GXP
Seatpost	Whyte 20mm Offset, 30.9mm x 400mm, 6061 Alloy, 2 Bolt Clamp	Whyte 20mm Offset, 30.9mm x 400mm, 6061 Alloy, 2 Bolt Clamp	Whyte 20mm Offset, 30.9mm x 400mm, 6061 Alloy, 2 Bolt Clamp	Whyte 20mm Offset, 27.2mm x 350mm, 6061 Alloy, 2 Bolt Clamp
Seat	Whyte Custom, Triple Panel Design	Whyte Custom Women's fit	Whyte Custom	Whyte Custom Kids
Bar	Whyte Riser Bar 30mm rise, 31.8mm, 680mm Wide	Whyte Riser Bar 30mm rise, 31.8mm, 680mm Wide	Whyte Riser Bar 30mm rise, 31.8mm, 680mm Wide	Whyte Flat Kids Bar, 31.8mm, 580mm Wide
Stem	Whyte Custom, 70mm S, 70mm M, 90mm L & XL	Whyte Custom, 70mm S, 70mm M, 90mm L & XL	Whyte Custom, 70mm S, 70mm M, 90mm L & XL	Whyte Custom, 70mm -6 Deg
Grips	Whyte Custom Lock-on	Whyte Custom Lock-on	Whyte Custom Lock-on	SRAM Lock-On's
Front Brake	Avid Elixir 1, 160mm Rotor	Tektro HDC 300, 160mm rotor	Tektro HDC 300, 160mm rotor	Tektro HDC 330, 160mm rotor
Rear Brake	Avid Elixir 1, 160mm Rotor	Tektro HDC 300, 160mm rotor	Tektro HDC 300, 160mm rotor	Tektro HDC 330, 160mm rotor
Brake Levers	Avid Elixir 1	Tektro HDC 300	Tektro HDC 300	Tektro HDC 330 WDS, Adjustable Reach
Pedals	VP Composite with Alloy Cage and Toe Clip	VP Composite with Alloy Cage and Toe Clip	VP Composite with Alloy Cage and Toe Clip	VP Composite Kids

Specification details were correct at the time of printing. However, product changes may occur after this time. Please check model availability and full specification details with your dealer prior to ordering.

	CARBON HT			XC HT
Model	29-C Team	29-C S	29-C	729
Colour	Matt UD Carbon/Burnt Orange	Matt UD Carbon/Apple	Matt UD Carbon/Aqua	Matt Granite/Apple
Sizes Available	S, M, L	S, M, L	S, M, L	S, M, L
Frame	Uni-directional Multi Monocoque with internal cable routing, Post Mount chainstay mounted disk brake and full carbon dropouts	Uni-directional Multi Monocoque with internal cable routing, Post Mount chainstay mounted disk brake and full carbon dropouts	Uni-directional Multi Monocoque with internal cable routing, Post Mount chainstay mounted disk brake and full carbon dropouts	6061 Hydro Formed T6 Aluminium, Custom Drawn, Multi Butted with Post Mount Dropouts
Fork	Fox Float 32 Factory, 100mm Travel with CTD Adjust, FIT, Tapered steerer and 15QR	RockShox Sid RL, 100mm Travel, 15mm Maxle Lite, Matchmaker PushLock Remote lockout	RockShox Reba RL, 100mm Travel, Tapered Steerer, Crown Activated Lockout	RockShox Reba RL 100mm Travel, Alloy Tapered Steerer, 15mm Maxle, Rebound and Compression adjust
Headset	FSA Integrated, Orbit ZS Plus, 1 1/8" - 1 1/2" Sealed Cartridge Bearings	FSA Integrated, Orbit ZS Plus, 1 1/8" - 1 1/2" Sealed Cartridge Bearings	FSA Integrated, Orbit ZS Plus, 1 1/8" - 1 1/2" Sealed Cartridge Bearings	FSA No. 10 upper and 1.5" lower external cup with Cartridge Bearings
Rear Hub	Whyte XC-209-C Team Wheelset, 28 Straight Pull StSt spokes, Alloy Freehub, 6 Bolt hub with double sealed cartridge bearings	Whyte XC-209-C Carbon Wheelset, 32 StSt spokes, 6 Bolt hub with double sealed cartridge bearings	Alloy, Double Sealed Cartridge Bearings, with CNC Machined pockets, 32 Hole	Whyte XC-209 Wheelset, 32 StSt flat spokes, 6 Bolt hub with double sealed cartridge bearings
Front Hub	Whyte XC-209-C Team Wheelset, 28 Straight Pull StSt spokes, 6 Bolt hub with double sealed cartridge bearings	Whyte XC-209-C Carbon Wheelset, 28 StSt spokes, 6 Bolt hub with double sealed cartridge bearings	Alloy, Double Sealed Cartridge Bearings, Oversize 28mm hub flanges, CNC Machined pockets, 32 Hole	Whyte XC-209 Wheelset, 28 StSt flat spokes, 6 Bolt hub, double sealed cartridge bearing
Spokes	Black Stainless Steel Spokes, DT Swiss Prolock Alloy Nipples	Stainless Steel	WTB 15g, Black Stainless with Brass Nipples	Black Stainless Steel Spokes
Rims	Whyte X-C-209-C Team Uni-Directional High-Modulus Carbon, 23mm wide, Tubeless Ready	Whyte X-C-209-C Uni-Directional High-Modulus Carbon, 23mm wide, Tubeless Ready	Whyte X-C 229-S, Sleeve Joint	Whyte XC-209, welded joint
Tyres	Maxxis IKON, 120TPI Folding Bead, 29" x 2.2"	Maxxis IKON, 120TPI Folding Bead, 29" x 2.2"	Maxxis IKON, 60TPI Folding Bead, 29" x 2.2"	Maxxis IKON, 120TPI, 29" X 2.2" Folding
Shift Levers	Shimano XT I Spec, 10 Speed	Shimano SLX I Spec, 10 Speed	SRAM X-9 Matchmaker, 10 Speed	SRAM X-9 Matchmaker, 10 Speed, Custom Green
Front Derailleur	Shimano XT, 10 Speed, High Direct Mount	Shimano SLX, 10 Speed, High Direct Mount	SRAM X-5, 10 Speed, High Direct Mount	SRAM X-7, 10 Speed
Rear Derailleur	Shimano XTR M985, Shadow Plus, 10 Speed	Shimano XT M786, Shadow Plus, 10 Speed	SRAM X-9 Type 2 medium Cage, 10 Speed, White/Black	SRAM X-9 Type 2, Medium Cage, 10 Speed Custom Green
Cassette	Shimano XT CS-M771, 11-36, 10 Speed	Shimano SLX CS-HG81, 11-36, 10 Speed	SRAM PG-1030, 11-36, 10 Speed	SRAM PG-1050, 11-36, 10 Speed
Chain	FSA Team Issue, 10 Speed	Shimano, HG54, 10 Speed	SRAM 1031 with Power Link, 10 Speed	SRAM PC 1031, 10 Speed
Crankset	FSA SL-K UD Carbon, PressFit30, 38-24 29er Ratio, Compact Double, 10 Speed	FSA SL-K UD Carbon, PressFit30, 38-24 29er Ratio, Compact Double, 10 Speed	SRAM S1000 PressFit30, 38/24, 29er Ratio, Compact Double, 10 Speed	SRAM S1400 GXP, 38-24 29er Ratio, Compact Double, 10 Speed
Bottom Bracket	FSA PressFit 30	FSA PressFit 30	SRAM PressFit 30	SRAM GXP
Seatpost	FSA SL-K, UD Carbon, 30.9mm x 400mm	Whyte Custom 2014 Alloy, 30.9mm x 400mm, 2 bolt clamp	Whyte Custom 2014 Alloy, 30.9mm x 400mm, 2 bolt clamp	Whyte 20mm Offset, 30.9mm x 400mm, 2014 Alloy, 2 Bolt Clamp
Seat	Fi'zi:k Tundra II, Mag Rails	Whyte Custom dual density, triple panel design	Whyte Custom dual density, triple panel design	Whyte Custom dual density, triple panel design
Bar	FSA SL-K UD Carbon Flat Bar, 31.8mm, 700mm Wide	FSA SL-K UD Carbon, Flat Bar, 31.8mm, 700mm Wide	Whyte Custom 6061 Alloy, Flat, 31.8mm, 700mm Wide	Whyte Flat 29er 2014 Bar, 31.8mm, 700mm Wide
Stem	Whyte Custom, -6 Degree, 70mm S and M and 80mm L	Whyte Custom, -6 Degree, 70mm S and M and 80mm L	Whyte Custom, -6 Degree, 70mm S and M and 80mm Large	Whyte Custom, -6 Degree, 70mm S and M and 80mm Large
Grips	Whyte Lock-on, EVA Light-weight Foam	Whyte Lock-on, EVA Light-weight Foam	Whyte Lock-on, EVA Light-weight Foam	Whyte Custom Lock-on
Front Brake	Shimano XT, 180mm Rotor	Shimano SLX I Spec, 180mm Rotor	Avid Elixir 3, Matchmaker, 170mm Rotor	Avid Elixir 5 Matchmaker, 170mm Rotor
Rear Brake	Shimano XT, 160mm Rotor	Shimano SLX I Spec, 160mm Rotor	Avid Elixir 3, Matchmaker, 160mm Rotor	Avid Elixir 5 Matchmaker, 160mm Rotor
Brake Levers	Shimano XT I-Spec	Shimano SLX	Avid Elixir 3	Avid Elixir 5 Matchmaker
Pedals	N/A	N/A	N/A	N/A



	XC HT		LIGHTWEIGHT CLASSIC	C7 ALL TERRAIN
Model	629	529	Strawberry Hill Ladies	Caledonian Ladies
Colour	Matt White/Aqua	Matt Granite/Burnt Orange	Granite/Plum	Matt Bone/ Silver
Sizes Available	S, M, L	S, M, L	S, M, L	S, M, L
Frame	6061 Hydro Formed T6 Aluminium, Custom Drawn, Multi Butted with Post Mount Dropouts	6061 Hydro Formed T6 Aluminium, Custom Drawn, Multi Butted with Post Mount Dropouts	6061 Hydro Formed T6 Aluminium, Custom Drawn, Multi Butted with Custom Whyte Dropouts	6061 Hydro Formed T6 Aluminium, Custom Drawn, Multi Butted with Custom Whyte Dropouts
Fork	RockShox XC-30 TK 29, 100mm Travel, Alloy Tapered Steerer and Lock out and rebound	RockShox XC-28, 100mm Travel, Adjustable Rebound, Turn Key Lockout	Whyte Alloy, curved blade with Alloy Steerer	SR Suntour NCX-D LO Lite, 63mm travel, Coil Spring, Hydro Lockout and Alloy steerer tube
Headset	FSA No. 10 upper and 1.5" lower external cup Caged Bearings	FSA No. 10 Caged Bearings	FSA Semi Integrated, 1 1/8" Sealed Cartridge Bearings	FSA Semi Integrated, 1 1/8" Sealed Cartridge Bearings
Rear Hub	Whyte Alloy Double Sealed 32 Hole Rear, 28 Hole Front	Alloy, Double Sealed Bearing Hub, 32 Hole	Alloy, Double Sealed Bearing, 32 Hole	Alloy, Double Sealed Bearing, 32 Hole
Front Hub	Whyte Alloy Cartridge Bearing hub with 28mm Flange 32 Hole	Alloy, Double Sealed Bearing Hub, 32 Hole	Alloy, Double Sealed Bearing, 32 Hole	Alloy, Double Sealed Bearing, 32 Hole
Spokes	WTB 15g, Black Stainless with Brass Nipples	WTB 15g, Black Stainless with Brass Nipples	WTB 15g, Silver Stainless with Brass Nipples	WTB 15g, Black Stainless with Brass Nipples
Rims	Whyte XC-229 sleeve joint Rims, 32 Hole Rear, 28 Hole Front	Whyte XC-29, sleeve joint rims, 32 Hole	Whyte Double Walled Alloy, 700c, 32 Hole	WTB SX-17 700c, 32 Hole, with eyelets
Tyres	Maxxis IKON 60TPI, 29"x 2.2", Folding	Maxxis IKON 60TPI, 29"x 2.2", Folding	Maxxis Roamer, 700 x 42c High Air Volume, with Kevlar Puncture Guard	WTB All Terrain Comp 700 x 35c, Folding with Flat Guard
Shift Levers	SRAM X-5, 10 Speed	Shimano Acera, 9 Speed	Shimano Altus, 9 Speed	Shimano Alivio, 9 Speed
Front Derailleur	SRAM X-5, 10 Speed	Shimano Altus, 9 Speed	Shimano Altus, 9 Speed	Shimano Acera, 9 Speed
Rear Derailleur	SRAM X-7, Type 2, Medium Cage, 10 Speed	Shimano Deore RD-M592 Shadow	Shimano Acera, 9 Speed	Shimano Deore Shadow
Cassette	SRAM PG-1030, 11-36, 10 Speed	Shimano HG-30, 11-34, 9 Speed	Shimano HG-30, 11-34, 9 Speed	Shimano CS-HG-30, 11-32, 9 Speed
Chain	SRAM PC 1031, 10 Speed	KMC X9, 9 Speed	Shimano HG-53, 9 Speed	Shimano HG-53, 9 Speed
Crankset	SRAM S1000 GXP, 38-24 29er Ratio, Compact Double, 10 Speed	Shimano M391, 44-32-22, 9 Speed, Octalink	Shimano M391 Acera, 48-36-26	Shimano Acera M391, 48-36-26, Octalink
Bottom Bracket	SRAM GXP	Shimano BB-ES25 Octalink	Square Taper	Shimano ES-25 Octalink
Seatpost	Whyte 20mm Offset, 30.9mm x 400mm, 2014 Alloy, 2 Bolt Clamp	Whyte 20mm Offset, 30.9mm x 400mm, 6061 Alloy, 2 Bolt Clamp	Whyte 20mm Offset, 30.9mm x 350mm, 6061 Alloy, With 2 Bolt Clamp	Whyte 20mm Offset, 30.9mm x 400mm, 6061 Alloy, 2 bolt clamp
Seat	Whyte Custom, Triple Panel Design	Whyte Custom, Triple Panel Design	Selle Royal, Milo Women's fit Saddle	Whyte Custom Women's Fit, triple panel design With Snake Skin effect
Bar	Whyte Flat 29er 6061 Bar, 31.8mm, 700mm Wide	Whyte Flat 29er 6061 Bar, 31.8mm, 700mm Wide	Whyte Swept Bar, 25.4mm, 600mm Wide, 45mm Sweep	Whyte High Rise 30mm, 31.8mm, 620mm Wide
Stem	Whyte Custom, -6 Degree, 70mm S and M and 80mm Large	Whyte Custom, -6 Degree, 70mm S and M and 80mm Large	Whyte Custom, High Rise	Whyte Custom, 70mm S, 80mm M, 90mm L
Grips	Whyte Custom Lock-on	Whyte Custom Lock-on	GP1 Ergon, Swept Bar specific	Whyte Custom Ergo Dual Density Lock-on's
Front Brake	Avid Elixir 1, 170mm Rotor	Tektro HDC330, 160mm rotor	Tektro Forged V Brake	Tektro HCD330 WDS, 160mm Rotor
Rear Brake	Avid Elixir 1, 160mm Rotor	Tektro HDC330, 160mm rotor	Tektro Forged V Brake	Tektro HCD330 WDS, 160mm Rotor
Brake Levers	Avid Elixir 1	Tektro HDC330	Tektro V Brake Levers with Integrated Bell	Tektro HCD330 WDS
Pedals	VP Full Alloy with Toe Clip	VP Composite with Alloy Cage and Toe Clip	VP Alloy Body with Non Slip Grip	VP Composite with Alloy Cage and Toe Clip

Specification details were correct at the time of printing. However, product changes may occur after this time. Please check model availability and full specification details with your dealer prior to ordering.

C7 ALL TERRAIN				
Model	Malvern Ladies	Chiltern	Caledonian	Malvern
Colour	Matt Granite/Silver	Matt Granite/Apple	Matt Zinc/Aqua	Matt Granite/Silver
Sizes Available	S, M, L	S, M, L	S, M, L	S, M, L, XL
Frame	6061 Hydro Formed T6 Aluminium, Custom Drawn, Multi Butted with Custom Whyte Dropouts	6061 Hydro Formed T6 Aluminium, Custom Drawn, Multi Butted with Custom Whyte Dropouts	6061 Hydro Formed T6 Aluminium, Custom Drawn, Multi Butted with Custom Whyte Dropouts	6061 Hydro Formed T6 Aluminium, Custom Drawn, Multi Butted with Custom Whyte Dropouts
Fork	SR Suntour NEX HLO, 63mm travel with Hydro Lockout	SR Suntour NCX-E LO Lite, 63mm travel, Air Spring, Hydro Lock-out, Alloy Upper legs with Alloy Steerer	SR Suntour NCX-D LO Lite, 63mm travel, Coil Spring, Hydro Lockout and Alloy Steerer tube	SR Suntour NEX HLO, 63mm travel, Hydro Lockout
Headset	FSA Semi Integrated, 1 1/8" Sealed Cartridge Bearings	FSA Semi Integrated, 1 1/8" Sealed Cartridge Bearings	FSA Semi Integrated, 1 1/8" Sealed Cartridge Bearings	FSA Semi Integrated, 1 1/8" Sealed Cartridge Bearings
Rear Hub	Alloy, Double Sealed Bearing, 32 Hole	Alloy, Double Sealed Cartridge Bearings, 32 Hole	Alloy, Double Sealed Bearings, 32 Hole	Alloy, Double Sealed Bearing, 32 Hole
Front Hub	Alloy, Double Sealed Bearing, 32 Hole	Alloy, Double Sealed Cartridge Bearings, 32 Hole	Alloy, Double Sealed Bearings, 32 Hole	Alloy, Double Sealed Bearing, 32 Hole
Spokes	WTB 15g, Silver Stainless with Brass Nipples	DT Champion 15g Black Stainless with Black Brass Nipples	WTB 15g, Black Stainless with Brass Nipples	WTB 15g, Silver Stainless with Brass Nipples
Rims	WTB SX-17 700c, 32 Hole, with eyelets	WTB SX-17 700c, 32 Hole with Eyelets	WTB SX-17 700c, 32 Hole, with eyelets	WTB SX-17 700c, 32 Hole, with eyelets
Tyres	WTB All Terrain Comp 700 x 35c with Flat Guard	WTB All Terrain Comp 700 x 35c, Folding with Flat Guard and Reflective Sidewalls	WTB All Terrain Comp 700 x 35c, with Flat Guard	WTB All Terrain Comp 700 x 35c with Flat Guard
Shift Levers	Shimano Acera, 9 Speed	Shimano Deore, 10 Speed	Shimano Alivio, 9 Speed	Shimano Acera, 9 Speed
Front Derailleur	Shimano Altus, 9 Speed	Shimano Deore, 10 Speed	Shimano Acera, 9 Speed	Shimano Altus, 9 Speed
Rear Derailleur	Shimano Alivio, 9 Speed	Shimano XT, 10 Speed	Shimano SLX Shadow	Shimano Alivio, 9 Speed
Cassette	Shimano CS-HG-20, 11-32, 9 Speed	Shimano CS-HG62, 11-34, 10 Speed	Shimano Alivio HG-30, 11-32, 9 Speed	Shimano HG-20, 11-32, 9 Speed
Chain	Shimano HG-53, 9 Speed	Shimano HG-54, 10 Speed	Shimano HG-53, 9 Speed	Shimano HG-53, 9 Speed
Crankset	Shimano M391 Acera, 48-36-26	Shimano T551, Hollow Tech II, 48-36-26, 10 Speed	Shimano Acera M391, 48-36-26, Octalink	Shimano M391 Acera, 48-36-26
Bottom Bracket	Square Taper	Shimano, Hollow Tech II	Shimano ES-25 Octalink	Square Taper
Seatpost	Whyte 20mm Offset, 30.9mm x 400mm, 6061 Alloy, 2 bolt clamp	Whyte 20mm Offset, 30.9mm x 400mm, 6061 Alloy, 2 bolt clamp	Whyte 20mm Offset, 30.9mm x 400mm, 6061 Alloy, 2 bolt clamp	Whyte 20mm Offset, 30.9mm x 400mm, 6061 Alloy, With 2 Bolt Clamp
Seat	Whyte Custom Women's Fit, triple panel design With Snake Skin effect	Whyte Custom, triple panel design	Whyte Custom, triple panel design	Whyte Custom, triple panel design
Bar	Whyte High Rise 30mm, 31.8mm, 620mm Wide	Whyte High Rise 30mm, 31.8mm, 620mm Wide	Whyte High Rise 30mm, 31.8mm, 620mm Wide	Whyte High Rise 30mm, 31.8mm, 620mm Wide
Stem	Whyte Custom, 70mm S, 80mm M, 90mm L	Whyte Custom, 70mm S, 80mm M, 90mm L	Whyte Custom, 70mm S, 80mm M, 90mm L	Whyte Custom, 70mm S, 80mm M, 90mm L
Grips	Whyte Custom Ergo Dual Density Lock-on's	Whyte Custom Ergo Dual Density Lock-on's	Whyte Custom Ergo Dual Density Lock-on's	Whyte Custom Ergo Dual Density Lock-on's
Front Brake	Tektro HDC 300, 160mm Rotor	Shimano 446, 160mm Rotor	Shimano M446, 160mm Rotor	Tektro HDC 300, 160mm Rotor
Rear Brake	Tektro HDC 300, 160mm Rotor	Shimano 446, 160mm Rotor	Shimano M446, 160mm Rotor	Tektro HDC 300, 160mm Rotor
Brake Levers	Tektro HDC 300	Shimano 445	Shimano M445	Tektro HDC 300
Pedals	VP Composite with Toe Clip	VP Full Alloy with Toe Clip	VP Composite with Alloy Cage and Toe Clip	VP Composite with Toe Clip



R7 FAST URBAN				
Model	Pimlico Women's	Victoria Women's	Montpellier	Stirling
Colour	Matt Plum/Grey	Matt Granite/Aqua	Matt UD Black/Gloss Black	Matt Granite/Burnt Orange
Sizes Available	S, M, L	S, M, L	M, L, XL	S, M, L, XL, XXL
Frame	6061 Hydro Formed T6 Aluminium, Custom Drawn, Multi Butted with Custom Whyte Dropouts	6061 Hydro Formed T6 Aluminium, Custom Drawn, Multi Butted with Custom Whyte Dropouts	Full Carbon Monocoque with tapered headtube and internal cable routing	6061 Hydro Formed T6 Aluminium, Custom Drawn, Multi Butted with Custom Whyte Dropouts
Fork	Straight Bladed Carbon Front Fork, with Single Eyelets	Straight Bladed 6061 T6 Alloy Front Fork, with Single Eyelets	Straight Bladed Carbon Front Fork with Alloy Tapered Steerer and single eyelet	Straight Bladed Carbon Front Fork with Alloy Steerer Tube, Single Eyelets
Headset	FSA Integrated Road, 1 1/8" Sealed Cartridge Bearings, 41mm Diameter	FSA Integrated Road, 1 1/8" Sealed Cartridge Bearings, 41mm Diameter	FSA Integrated Road, 1 1/8" upper Sealed Cartridge Bearing, 1.5 lower Sealed Cartridge Bearing	FSA No23 Integrated Road, 1 1/8" Sealed Cartridge Bearings, 41mm Diameter
Rear Hub	Alloy, Double Sealed Bearing Hub, 32 Hole	Alloy, Double Sealed Bearing Hub, 32 Hole	Alloy, Double Sealed Cartridge Bearing Hub, 32 Hole	Alloy, Double Sealed Cartridge Bearing Hub, 32 Hole
Front Hub	Alloy, Double Sealed Bearing Hub, 28 Hole	Alloy, Double Sealed Bearing Hub, 28 Hole	Alloy, Double Sealed Cartridge Bearing Hub, 28 Hole	Alloy, Double Sealed Cartridge Bearing Hub, 28 Hole
Spokes	WTB PG 15g, Black Stainless with Brass Nipples	WTB PG 15g, Black Stainless with Brass Nipples	DT Champion, 1.8mm Black Stainless with Brass Nipples	DT Champion, 1.8mm Black Stainless with Brass Nipples
Rims	Alex Black Dragon 24, Deep Section, Disk Specific Road, 32 Hole Rear and 28 Front, Reflective 3M decals	Alex Black Dragon 24, Deep Section, Disk Specific Road, 32 Hole Rear and 28 Front, Reflective 3M decals	Alex Black Dragon 24, Deep Section, Disk Specific Road, 32 Hole Rear and 28 Front, Reflective 3M decals	Alex Black Dragon 24, Deep Section, Disk Specific Road, 32 Hole Rear and 28 Front, Reflective 3M decals
Tyres	Maxxis Detonator, 700 x 28c, Folding Black/Grey, with Puncture Protection	Maxxis Detonator, 700 x 28c, Folding Black/Grey, with Puncture Protection	Maxxis Detonator, 700 x 28c, Grey, Folding with Puncture Protection	Maxxis Detonator, 700 x 28c, Grey, Folding with Puncture Protection
Shift Levers	SRAM Via Centro, 10 Speed	Shimano Sora SL-3500, 9 Speed	SRAM Via GT, Matchmaker, 10 Speed	SRAM Via GT, 10 Speed
Front Derailleur	SRAM Via Centro, 10 Speed	Shimano Sora FD-R3500, 9 Speed	SRAM Via GT 10 Speed	SRAM Via Centro, 10 Speed
Rear Derailleur	SRAM Via Centro, 10 Speed	Shimano Sora RD-3500, 9 Speed	SRAM Via GT 10 Speed	SRAM Via GT, 10 Speed
Cassette	SRAM PG-1030, 11-32, 10 Speed	SRAM PG-950, 11-32 9 Speed	SRAM PG-1050, 11-32, 10 Speed	SRAM PG-1030, 11-32, 10 Speed
Chain	SRAM PC-1031, 10 Speed	Shimano HG-53, 9 Speed	SRAM PC-1031, 10 Speed	SRAM PC-1031, 10 Speed
Crankset	SRAM Via Centro, 48-32, 10 Speed, Compact	FSA Tempo 50:34, 9 Speed, Compact, 170mm Crank arm length	SRAM Via GT, 48-32 Urban Compact, 10 Speed	SRAM Via GT, 48-32 Urban Compact, 10 Speed
Bottom Bracket	SRAM Power Spline, 68mm Shell	FSA Square Taper	SRAM GXP	SRAM GXP
Seatpost	Whyte 20mm Offset, 27.2mm x 350mm, 6061 Alloy, 2 Bolt Clamp	Whyte 20mm Offset, 27.2mm x 350mm, 6061 Alloy, 2 Bolt Clamp	Whyte 20mm Offset, 27.2mm x 350mm, 2014 Alloy, 2 Bolt Clamp	Whyte 20mm Offset, 27.2mm x 350mm, 2014 Alloy, 2 Bolt Clamp
Seat	Whyte Custom Women's Fit, Triple Panel Design with Snake Skin Cover	Whyte Custom Women's Fit, Triple Panel Design with Snake Skin Cover	Whyte Custom, Triple Panel Design	Whyte Custom, Triple Panel Design, Black Snake Skin Cover
Bar	Whyte Narrow, 31.8mm, 20mm Rise, 580mm Wide	Whyte Narrow, 31.8mm, 20mm Rise, 580mm Wide	Whyte Narrow, 31.8mm, Flat Bar, 580mm Wide	Whyte Narrow, 31.8mm, 20mm Rise, 580mm Wide
Stem	Whyte, 70mm XS & S, 80mm M	Whyte, 70mm XS & S, 80mm M	Whyte, 80mm M, 90mm L & XL	Whyte, 70mm S, 80mm M, 90mm L & XL
Grips	Whyte double Density, Lock-on	Whyte double Density, Lock-on	GP1 Ergon Grip, Dual Density	GP1 Ergon, Dual Density
Front Brake	Tektro Draco 2, Light weight 160mm Rotor	Tektro HDC300, Light weight 160mm Rotor	SRAM Via GT, 160mm Rotor	Avid DB-1, 160mm Rotor
Rear Brake	Tektro Draco 2, Light weight 160mm Rotor	Tektro HDC300, Light weight 160mm Rotor	SRAM Via GT, 160mm Rotor	Avid DB-1, 160mm Rotor
Brake Levers	Tektro Draco 2	Tektro HDC300	SRAM Via GT, Matchmaker	Avid DB-1
Pedals	Composite with Alloy Cage and Toe Clip	Composite with Alloy Cage and Toe Clip	None	Full Alloy with Toe Clip

Specification details were correct at the time of printing. However, product changes may occur after this time. Please check model availability and full specification details with your dealer prior to ordering.

	R7 FAST URBAN		ROAD DISK	
Model	Cambridge	Portobello	Suffolk	Dorset
Colour	Matt Zinc/Aqua	Matt Granite/Apple	Matt Granite/Burnt Orange	Matt Zinc/Apple
Sizes Available	S, M, L, XL	S, M, L, XL, XXL	50cm, 52cm, 54cm, 56cm, 58cm	50cm, 52cm, 54cm, 56cm, 58cm
Frame	6061 Hydro Formed T6 Aluminium, Custom Drawn, Multi Butted with Custom Whyte Dropouts	6061 Hydro Formed T6 Aluminium, Custom Drawn, Multi Butted with Custom Whyte Dropouts	6061 Hydro Formed T6 Aluminium, Custom Drawn, Multi Butted with Post Mount Chainstay Disk mount	6061 Hydro Formed T6 Aluminium, Custom Drawn, Multi Butted with Post Mount Chainstay Disk mount
Fork	Straight Bladed Carbon Front Fork, with Single Eyelets	Straight Bladed 6061 T6 Alloy Front Fork, with Single Eyelets	Straight Bladed Carbon Front Fork, with Eyelets, Post Mount disk mount, Tapered Steerer	Straight Bladed Carbon Front Fork, with Eyelets, Post Mount disk mount, Tapered Steerer
Headset	Integrated Road, 1 1/8" Sealed Cartridge Bearings, 41mm Diameter	FSA Integrated Road, 1 1/8" Sealed Cartridge Bearings, 41mm Diameter	FSA Integrated Road, 1 1/2" lower and 1 1/8" upper Sealed Cartridge Bearings	FSA Integrated Road, 1 1/2" lower and 1 1/8" upper Sealed Cartridge Bearings
Rear Hub	Alloy, Double Sealed Bearing Hub, 32 Hole	Alloy, Double Sealed Bearing Hub, 32 Hole	Alloy, Double Sealed Cartridge Bearing Hub, 32 Hole	Alloy, Double Sealed Cartridge Bearing Hub, 32 Hole
Front Hub	Alloy, Double Sealed Bearing Hub, 28 Hole	Alloy, Double Sealed Bearing Hub, 28 Hole	Alloy, Double Sealed Cartridge Bearing Hub, 28 Hole	Alloy, Double Sealed Cartridge Bearing Hub, 28 Hole
Spokes	WTB PG 15g, Black Stainless with Brass Nipples	WTB PG 15g, Black Stainless with Brass Nipples	WTB PG 15g, Black Sandvik Stainless with Black Brass Nipples	WTB PG 15g, Black Sandvik Stainless with Black Brass Nipples
Rims	Alex Black Dragon 24, Deep Section, Disk Specific Road, 32 Hole Rear and 28 Front, Reflective 3M decals	Alex Black Dragon 24, Deep Section, Disk Specific Road, 32 Hole Rear and 28 Front, Reflective 3M decals	Alex Black Dragon 24, Deep Section, Disk Specific Road, 32 Hole Rear and 28 Front, Reflective 3M decals	Alex Black Dragon 24, Deep Section, Disk Specific Road, 32 Hole Rear and 28 Front, Reflective 3M decals
Tyres	Maxxis Detonator, 700 x 28c, Grey, Folding with Puncture Protection	Maxxis Detonator, 700 x 28c, Black, with Puncture Protection	Maxxis Detonator, 700 x 28c, Black/Grey, with Puncture Protection, Folding	Maxxis Detonator, 700 x 28c, Black/Grey, with Puncture Protection, Folding
Shift Levers	SRAM Via Centro, 10 Speed	Shimano Sora SL-3500, 9 Speed	Shimano ST-5700 10S, 10 Speed	Shimano ST-4600 Tiagra, 10 Speed
Front Derailleur	SRAM Via Centro, 10 Speed	Shimano Sora FD-3500, 9 Speed	Shimano FD-4600 Tiagra, 10 Speed	Shimano FD-4600 Tiagra, 10 Speed
Rear Derailleur	SRAM Via Centro, 10 Speed	Shimano Sora RD-3500, 9 Speed	Shimano RD-5700 10S, 10 Speed	Shimano RD-4600 Tiagra, 10 Speed
Cassette	SRAM PG-1030, 11-32, 10 Speed	SRAM PG-950, 11-32 9 Speed	Shimano CS-4600 Tiagra 11-30, 10 Speed	Shimano CS-4600 Tiagra 11-30, 10 Speed
Chain	SRAM PC-1031, 10 Speed	Shimano HG-53, 9 Speed	Shimano CN-4601 Tiagra, 10 Speed	Shimano CN-4601 Tiagra, 10 Speed
Crankset	SRAM Via Centro, 48-32, 10 Speed, Compact	FSA Tempo 50-34, 9 Speed, Compact	FSA Gossamer 34-50, 10 Speed, Compact Double	FSA Omega 34-50, 10 Speed, Compact Double
Bottom Bracket	SRAM Power Spline, 68mm Shell	FSA Square Taper	FSA Mega Exo	FSA Mega Exo
Seatpost	Whyte 20mm Offset, 27.2mm x 350mm, 2014 Alloy, 2 Bolt Clamp	Whyte 20mm Offset, 27.2mm x 350mm, 6061 Alloy, 2 Bolt Clamp	Whyte 20mm Offset, 27.2mm x 350mm, 2014 Alloy, 2 Bolt Clamp	Whyte 20mm Offset, 27.2mm x 350mm, 6061 Alloy, 2 Bolt Clamp
Seat	Whyte Custom, Triple Panel Design, Dark Brown Snake Skin Cover	Whyte Custom, Triple Panel Design, Snake Skin Cover	Whyte Custom, Triple Panel Design	Whyte Custom, Triple Panel Design
Bar	Whyte Narrow, 31.8mm, 20mm Rise, 580mm Wide	Whyte Narrow, 31.8mm, 20mm Rise, 580mm Wide	Whyte Road, 31.8mm, Compact "Wing" Bar, 440mm Wide	Whyte Road, 31.8mm, Compact "Wing" Bar, 440mm Wide
Stem	Whyte, 70mm S, 80mm M, 90mm L & XL	Whyte, 70mm S, 80mm M, 90mm L & XL	Whyte -6 Deg, 100mm 52cm, 110mm 54cm/56cm, 120mm 57cm	Whyte -6 Deg, 100mm 52cm, 110mm 54cm/56cm, 120mm 57cm
Grips	Whyte Custom Dual Density Lock-on's	Whyte Custom Dual Density Lock-on's	Whyte Anti Slip, Cross Bar Tapes	Whyte Anti Slip, Cross Bar Tapes
Front Brake	Tektro Draco 2, 160mm Rotor	Tektro HDC300, Light weight 160mm Rotor	TRP HyRd, 160mm Rotor	Pro Max CX Mechanicals, Linear outer cables with Kevlar Reinforcement, 160mm Rotor
Rear Brake	Tektro Draco 2, 160mm Rotor	Tektro HDC300, Light weight 160mm Rotor	TRP HyRd, 160mm Rotor	Pro Max CX Mechanicals, Linear outer cables with Kevlar Reinforcement, 160mm Rotor
Brake Levers	Tektro Draco 2	Tektro HDC300	Shimano ST-5700	Shimano ST-4600
Pedals	Composite with Alloy Cage and Toe Clip	Composite with Alloy Cage and Toe Clip	Full Alloy with Toe Clip	Full Alloy with Toe Clip