



**WHYTE**  
PERFORMANCE BY DESIGN



DESIGNED IN THE U.K.



# 2011 CONTENTS

RESEARCH AND DEVELOPMENT	PAGES 5-6
MATERIALS	PAGES 7-8
CARBON TECHNOLOGY	PAGES 9-10
RACING	PAGES 11-12
FULL SUSPENSION	PAGES 13-24
QUAD-LINK II	PAGES 25-26
WHYTE 19 CARBON	PAGES 27-32
WHYTE TRAIL HARDTAILS	PAGES 33-40
WHYTE 19 DROPOUT	PAGES 41-42
GETTA GRIP	PAGES 41-42
WHYTE 905	PAGES 43-46
WHYTE 901	PAGES 47-48
X-8 PERFORMANCE XC HARDTAIL	PAGES 49-52
C7: ALL TERRAIN SERIES	PAGES 53-60
R7: FAST URBAN SERIES	PAGES 61-70
GEOMETRY	PAGES 71-73
SPECIFICATIONS	PAGES 74-78









# WHYTE

Designed in the UK - and test ridden on the UK's toughest trails to ensure the perfect ride.

More than a decade of insistent innovation and cutting edge development. Bike test awards and rave reviews on an annual basis. Something we're very proud of here at Whyte and the reason we're not resting on our laurels for 2011.

Pushing the accepted performance limits is our constant goal and having a small and streamlined design team makes us fast on our feet and uniquely responsive to rider demands and new technological opportunities. It means we build the bikes we all want to ride, not the ones accountants and marketing departments would tell us to.

So while our 2011 line is the biggest Whyte family ever we've lost none of that crucial focus. Our bikes still handle better, last longer and cope with the UK's uniquely challenging riding demands more easily than any others. It's just that now, even more riders like you - and like us - can find their perfect bike in our range.

Whyte 2011: Welcome to our biggest and best year ever.







# RESEARCH AND DEVELOPMENT

## PERFORMANCE BY DESIGN

Our R&D address might be in the Cotswolds, but our real test facilities are city streets and mountain trails all over the world.

We work out multi piece carbon lay ups through riding countless laps of Welsh trail centres but have them verified by our race team as far away as the dry riverbeds of Botswana. Our geometry is fractionally exact because we know it makes us faster, not because we've taken an average of what others have done. We confidently put a lifetime warranty on our suspension bearings, because we grind them through the same grit and grime you have to for thousands of hours a year. A CAD machine might make the final rendering, but that big lever on our unique seat clamp is there because we got sick of trying to shut a normal one with frozen fingers. We know the addition of Crud Catcher mounts to the 19 frame is a significant one for all of you, because it means our eyes sting less after our lunchtime ride and our tea isn't washing grit off our teeth.

We could go on, but you get the idea. Whyte are genuinely a small group of dedicated UK riders, determined to produce the best bikes we can and not afraid to break some rules and set some benchmarks along the way.

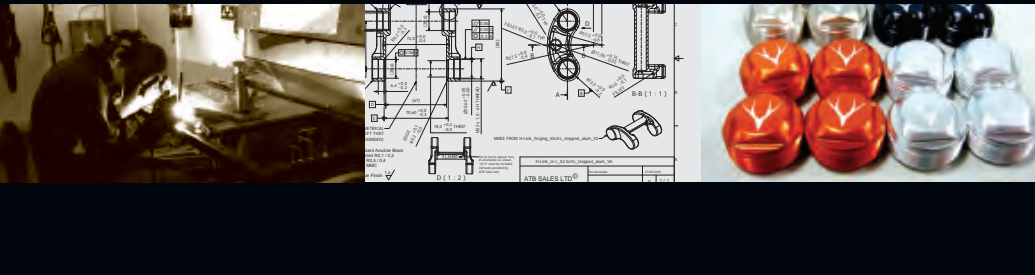





Chief Designer, Ian Alexander at the Whyte R&D office in Cheltenham, UK.



# MATERIALS

## CAREFULLY SELECTED FOR OPTIMUM PERFORMANCE

We make frames from Aluminium, Titanium, Steel and Carbon fibre as each of these materials have their own specific properties and their own particular ride characteristics.

Whether we are looking to create the super-stiff structure required for a full suspension bike or the lively and compliant ride that characterises a top quality steel frame, all the materials we use must have one thing in common - they have to be the best. Only then can we be sure we are achieving the best possible combination of strength and light weight and that the resulting frame will achieve the benchmark performance required by us and our customers.

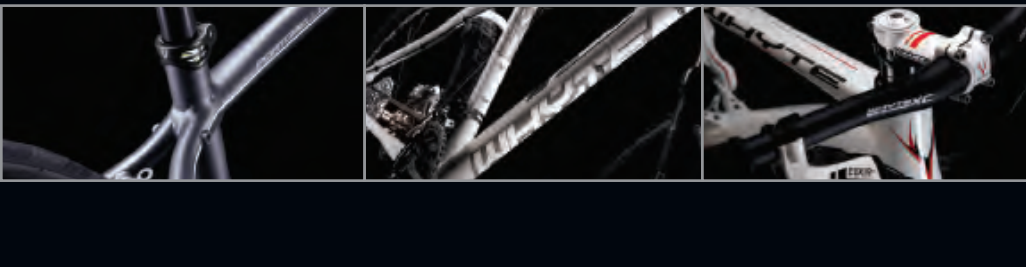

## TITANIUM

Titanium has what many believe to be the most sublime ride characteristics of any frame material so when we set out to design a Ti Hardtail, we knew it had to be special.

As with our eponymous aluminium Whyte 19, the UK designed titanium Whyte 19 Ti features new and exciting technology from the outset, and some elegant tube shapes too. We chose to couple a classic looking tubeset in cold worked 3AL-2.5V titanium with a simple and elegant seat stay design that does away with unnecessary welding and enhances the ride comfort and feel inherent in titanium, still further. Using longer, uninterrupted and curving tubes for the seat stays allows more trail feedback to disperse through the chassis and adds comfort compared with shorter tubes joined with unnecessary welds that are more commonly used in monostay designs. We also include the latest Press Fit 30 bottom bracket technology for lightweight additional stiffness, with long bearing life and finally our celebrated 19 dropout, allowing geometry adjustment and even hassle-free conversion to singlespeed transmission. Combining this technology with our very latest 19 Trail bike geometry and designed from the start for a 120mm travel fork, we have a lightweight responsive ride, with that legendary ride "feel" that only titanium can offer.



## STEEL

For the ultimate steel frame we went straight to the masters of steel tubing technology – Reynolds. Manufacturing butted tubing for bicycle frames in the UK since 1898, and still producing the high end tubesets like 631 in Birmingham, as they have for 110 years, Reynolds still push the boundaries of what is possible with steel like no other manufacturer.

Why 631? As we designed the frame for the steel Whyte, we were clear on a few essentials; the frame must be strong, light and stiff but still have that essential compliant and lively ride we expect from steel. It must also exceed CEN test standards (as all frames in the Whyte range do). 631 met all these criteria perfectly, and actually even exceeded 853 in back to back ride testing when we were trialing various prototypes to find the optimum ride feel – especially when combined with the classic and elegant compound bend rear stays we first used on the 19 Titanium.



## ALUMINIUM

For our aluminium trail frames, we use perhaps the ultimate refinement of aluminium alloy frame materials - specifically developed for use in hydro-forming and welded frame construction. Our selection of premium 6061 grades of aluminium allows us to use tubes of thinner wall section. This translates into thinner tube butting profiles over the entire length of tubes and means that for the same strength, stiffness and fatigue characteristics we can engineer a lighter chassis.

Whyte hydro-formed aluminium frame designs concentrate on designing the best most efficient shapes for the chassis. Our seatstays and chainstays have extensive shaping and tapering to increase strength and stiffness generating volume where it's needed, provide maximum mud clearance at key areas of the frame, as well as producing a frame that has a clean and elegant overall design profile. The hydro-forming design and production process gives us the best results in achieving the tough design criteria set out by the Whyte design team.

WHYTE MATERIALS  
PERFORMANCE BY DESIGN

# WHYTE CARBON TECHNOLOGY

AS FEATURED ON THE WHYTE 146, T-120s AND 19C

The performance of any carbon fibre component relies on three things - the quality of the raw material, the integrity of the design and the precision of the assembly. That's why at Whyte, we take complete control of the design process and then work closely with the world's best carbon manufacturers to bring our designs to life.

This close working relationship also means we can develop special combinations of filament grades and resin types to give our carbon frames a genuine performance advantage that others can't match, combined with performance you can trust.







WHYTE  
CARBON TECHNOLOGY

# WHYTE RACING

## PERFORMANCE BY DESIGN

Anyone can throw their shirt on the latest shaven legged wonder and win some races. We prefer our athletic ambassadors to be a little more real though.

OK, so the speed (under 23 whippet Billy Whenman and global racer Luke Smith) will come past you is scarcely believable. The relentless hour-after-hour velocity of multiple Enduro, Polaris and TransWales winner Steve Heading isn't good for others egos either. Their performance and passion is both an inspiration and an ideal development tool for us though.

These racers all clock up their victories and rack up training miles on proper tough technical trails and courses. They live and thrive in conditions where there is no place for compromise, second best or even a day off. An environment where several seconds gained on a descent repeated thirty times in 24 hrs are worth far, far more than a few shaved grams. Where consistently surefooted traction and rock solid power transfer enable you to clean climbs all the way to the top of a podium as effectively as they do in the Peak District. It's the reason our geometry is radically different from others default XC templates, which haven't changed since Flex Stems and fat tyres were the only suspension. Why we know an extra 20mm of travel can mean an extra 200m gained through every technical singletrack.

In other words we support racing that is relevant and gritty not just because we respect it more. We also do it because the trophies we win translate directly to you going further, faster and having more fun every time you ride. The durable and lightweight frames we produce have a relaxed race geometry which enables our athletes to hammer technical trails, sit in for long climbs and sprint with ease. Racers have relied on the traction and immediate power transfer our designs deliver and have the results to prove it. They have powered fire roads, cleaned technical climbs and descended with precision.



From his Under 23 Enduro Championship win to his amazing victory on the punishing steps of Paris, Whyte racer Billy Whenman pushes himself and his machinery harder and faster - and is an invaluable part of our development and testing process.





BILLY WHENMAN  
ON HIS WHYTE 19 RACE

WHYTE TEAM KIT available from the WHYTE website visit: [www.whytebikes.co.uk](http://www.whytebikes.co.uk)







# WHYTE FULL SUSPENSION

146 WORKS, 146 S & T-120 S

Every year competitors scramble to grab the limelight fleetingly by edging ever closer to the limits of usability and reliability. We don't want to play that game though.

We design our bikes to be ridden relentlessly hard and build an appreciation that borders on addiction. To repay your enthusiasm and effort with the tightest, most responsive and toughest trail bikes available. The QUAD-Link II suspension also creates a uniquely responsive drive and shock absorbing architecture while shielding the shock from mud and debris. The bearings have a lifetime warranty too and there's enough tyre room to cope with the worst claggy conditions in winter.

That means the shocking acceleration, glued traction and exceptional chaos proof control you'll experience on your first ride is guaranteed on every following ride however foul the conditions are.

Trail tough, technically tenacious, blisteringly fast – pick three.





# WHYTE 146

TYPICAL USAGE: TRAIL RIDING

A genre, redefined.

"One bike - every trail" is a pretty tough design brief, but it is exactly what we have achieved with the all new 146. We are setting new standards for Trail riding with unrivalled strength-to-weight and unmatched suspension performance. From your favourite descent to your toughest climb the lightweight and supremely agile full carbon fibre chassis will challenge you to constantly push harder and faster, leaving all your trail riding chums trailing in your wake.

Climb like an XC bike, descend like a downhill bike, the 146 provides confidence-inspiring, trail-taming geometry and genre-redefining performance that will exceed your expectations every time you ride.







# WHYTE 146 WORKS XX

TYPICAL USAGE: TRAIL RIDING



The 146 features the lightest and stiffest swingarm we've ever made - and we've made quite a few. Interchangeable dropouts with post-mount brake and 142x12 systems are future-proof and the ultra low-profile delta-link design improves mud clearance for more aggressive riding.





# WHYTE

PERFORMANCE BY DESIGN



- We use monocoque technology as it allows us to integrate key parts of the frame in one structure, rather than building separate parts and joining them together later. This has real performance benefits. It's the lightest way to produce a frame that is both stiff and strong.
- A full carbon tapered headtube gives us fantastic stiffness which delivers very accurate tracking and steering performance in both low and high speed use.
- 146mm of rear suspension travel. Complete bike weighs only 25.5lbs (medium size) without pedals.
- SRAM PF30 bottom bracket improves durability in UK conditions and integrated ISCG05 tabs allow you to easily change your setup to a single chainring with a chain device.

PF + 30



2011 SUSPENSION

WHYTE 146 WORKS XX



# WHYTE 146 S

TYPICAL USAGE: TRAIL RIDING





# WHYTE

PERFORMANCE BY DESIGN

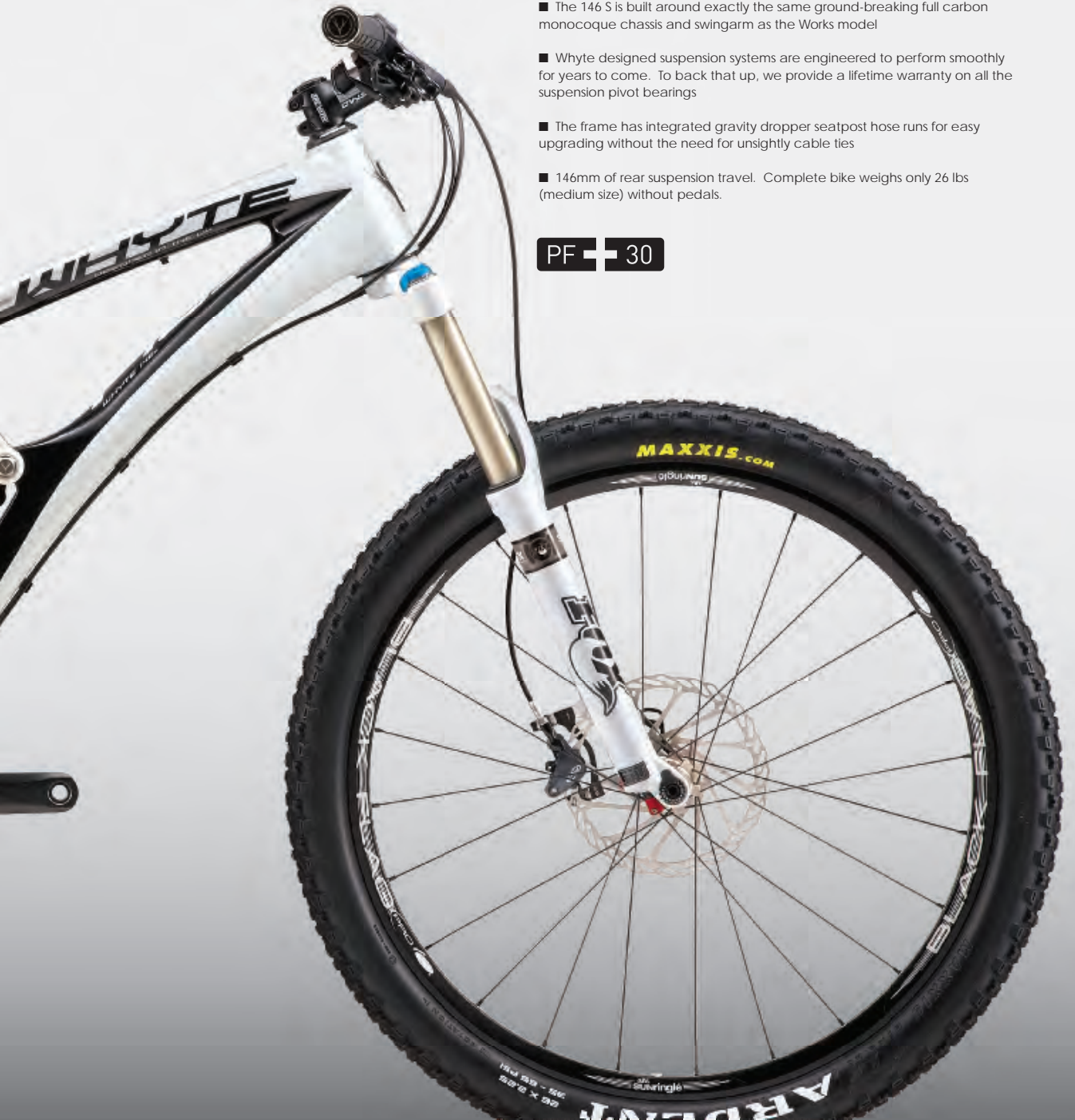

- The 146 S is built around exactly the same ground-breaking full carbon monocoque chassis and swingarm as the Works model
- Whyte designed suspension systems are engineered to perform smoothly for years to come. To back that up, we provide a lifetime warranty on all the suspension pivot bearings
- The frame has integrated gravity dropper seatpost hose runs for easy upgrading without the need for unsightly cable ties
- 146mm of rear suspension travel. Complete bike weighs only 26 lbs (medium size) without pedals.

PF + 30



2011 SUSPENSION WHYTE 146 S



# WHYTE T-120 S

## TYPICAL USAGE: TRAIL RIDING

Control the trail.

Set your saddle height via the uniquely comfortable, confidently secure broad lever seat clamp. Note how both seat slot and shock are completely protected from spray and debris. Relax into the saddle and take hold of the proper width bars with the full-fat semi lock-on grips, not limp featherweight foam. This is a proper, ultra practical trail bike.

Now take a deep breath. What happens next will be a surprise.

Immediate, unflinching power delivery. This bike doesn't just accelerate, it flies. Once unleashed it won't let go of that velocity either - it carves corners and swallows hits and drops so seamlessly that you'll be on the power through all your previous braking points. The T-120 is all about stability, confidence and control.







# WHYTE T-120 S

TYPICAL USAGE: TRAIL RIDING

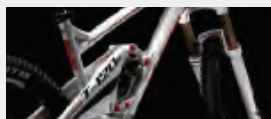

Typically, shocks on our bikes last longer, because they are protected from spray and trail debris. Lifetime guaranteed pivot bearings reduce stiction for unmatched small bump response.





# WHYTE

PERFORMANCE BY DESIGN



- Confidence inspiring handling is guaranteed with Whyte's Trail Geometry
- Custom drawn 6061 Aluminium main frame is light and strong
- Tapered headtube gives excellent front end stiffness which delivers accurate tracking and steering performance
- Full carbon single monocoque swingarm is light, strong and very stiff for exceptional power transfer and rear end stability. The replaceable dropouts come standard with the latest post-mount brake and 12 x 142 Maxle setup, but are interchangeable to future-proof the swingarm



2011 SUSPENSION WHYTE T-120 S



# WHYTE

PERFORMANCE BY DESIGN

## QUAD-LINK II SUSPENSION SYSTEM

QUAD-Link II takes all the simplicity and low weight benefits of a single pivot design to keep the bike totally rideable and reliable in the worst conditions you can throw at it. At the same time it removes all the inevitable compromises with carefully created controllable wheel paths and variable shock leverage ratios to maximise your control and enjoyment.

It drives, grips, sucks up small bumps, handles hits and keeps control better than any single pivot system, yet it copes with mud, lack of maintenance, gruelling grinding paste trails and future shock changes better than any other linkage design.

### SIMPLEST 4 BAR LINKAGE SYSTEM; UNIQUE & PATENTED

QUAD-Link II is the simplest 4-Bar Link system... In fact, there is less to it than most linkage assisted single pivot systems. QUAD-Link II bikes are unique and patent protected.

### INTELLIGENT WHEEL PATH DESIGN

The intelligent wheel path from our unique 4-Bar linkage architecture is key to the performance of our bikes. Initial rearward movement lets the wheel absorb the slap of square edged hits, maintaining momentum even at slow climbing speeds. It also keeps the bikes feeling sharp and connected under power. Reduced chain-growth deeper into the wheel path prevents pedalling interruption and control compromising kickback from bigger hits throughout the stroke.



## GENUINELY VARIABLE LEVERAGE RATIO: TUNED FOR THE TRAIL AHEAD.

Because of a carefully engineered relationship between leverage ratio, wheel path and chain-growth, QUAD-Link II suspension can use a minimally damped shock to give the plush, smoothest small bump response. The QUAD-Link II system then transitions smoothly through the mid-stroke of the shock to catch and control the biggest hits without ramping up or bottoming out harshly.



## EFFICIENT PEDALLING WITHOUT STIFLING LEVELS OF OVER DAMPING

At Whyte we've always believed in letting the shock do the best job of absorbing impacts that it can. Not choking small bump performance with excessive low speed compression damping or control-compromising 'platforms'.

Because we can tune each aspect of the suspension performance independently our bikes achieve great pedalling performance as well as excellent small bump absorption. Our intelligent wheel path pulls peak power into the ground exactly when and where you need it to give exceptional traction.

## LIFETIME WARRANTY ON PIVOT BEARINGS

The suspension system, the pivot bearings themselves and the way they install into the chassis are all specifically designed for maximum lifespan. That's why we can offer an unbeatable lifetime warranty on the pivot bearings of our bikes.

# WHYTE 19 CARBON

TYPICAL USAGE: CROSS COUNTRY, RACE

Speed doesn't come any more savage or seductive than this. While other companies offer off the peg frames, we provide off the chart performance.

We've worked hand in hand with the finest fibre suppliers and hand laid frame manufacturer to build a blisteringly fast chassis that's blown every tester and rider away. BB30 standard cranks harness every ounce of energy into forward motion. Curved lines leap from start lines and flow through singletrack with jaw and adversary dropping ease. Whyte's unique trail honed geometry lets you push the pace just as hard on the descents as the climbs too, making this the ultimate high velocity hardtail for raceheads or map shrinking maniacs.

With 4 complete bikes plus a frame kit in the range for 2011 its insistently predatory performance is more inclusive than ever.

The ultimate high velocity ride for real mountain bikers.







WHYTE

SWORKS

CARBON FRAME TECHNOLOGY

# WHYTE 19 WORKS XX

TYPICAL USAGE: CROSS COUNTRY, RACE



We've worked with the world's best manufacturers to find components that live up to the performance of our astonishing 19 Carbon frame.

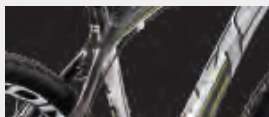



# WHYTE

PERFORMANCE BY DESIGN



■ The ultimate XC race bike, using the latest version of our multiple test winning frame is designed to win and will be used extensively by Whyte racing UK in 2011.

■ 2 x 10 SRAM XX shifting, FSA K-Force Light BB-30 cranks, Avid XX brakes, Rockshox Sid XX Suspension fork with 100mm travel and handlebar mounted X-loc motion control

■ Complete bike weight only 19 lbs (medium size)



2011 CARBON HT

WHYTE 19 WORKS XX



# WHYTE 19C

TYPICAL USAGE: CROSS COUNTRY, RACE



A race ready hardtail that can handle extreme trails, XC racing, or marathon riding - the 19 C does it all. Offering amazing mud clearance, the curved and beautifully crafted frame is the very pinnacle of carbon design and technology.



- Each of our 19 Carbon hardtails is built around exactly the same high specification frameset - all that changes are the parts.
- The 19 Team combines the exceptional Whyte carbon frameset with the very best from Shimano and an excellent FSA SLK Carbon crankset.
- The 19 CS features one of our favourite Fulcrum Wheelsets, SRAM X0 shifting and some choice FSA kit.
- Our unique geometry is more surefooted than a typical light-weight racer, inspiring confidence on more technical sections.

## WHYTE 19-C TEAM





WHYTE 19-C S



WHYTE 19-C







## WHYTE TRAIL HARDTAILS

19 Ti, 19 ALLOY, 19 STEEL, 905, 901

We feel sorry for the many people who don't 'get it'. Sorry for those riders whose full suspension bikes can't keep our trail hardtails in sight on descents, let alone singletrack. Sorry for those on race hardtails who've swallowed their tongues keeping pace with it on the climbs but who are now picking themselves out of the bushes on the exit of the first corner.

We'll even extend apologies to the designers who've tried and failed to match our unique hardtail handling elixir. An elusive mix as pitch perfect for blitzing trail centres, ripping up your riding group or vanishing into the wilds for a weekend.

What we don't apologise for is our outstanding 2011 Trail hardtail range. Award winning Ti 19, super versatile 19 Trail, multiple test winning and WMB magazine bike of the year recommended 905, the exceptional 901 alloy bike and Reynolds 631 tubed 19 Steel.







# WHYTE 19 TI

TYPICAL USAGE: CROSS COUNTRY, TRAIL



Shapely Ti stays please the eye and provide sublime ride characteristics. Clean lines, understated finish and an amazing spec make the 19 Ti a unique bike.





# WHYTE

PERFORMANCE BY DESIGN



■ The ultimate Ti hardtail features geometry acknowledged by our customers and independent reviewers as the best numbers in the business

■ Cold worked 3/2.5 for light weight, with the unique compliant, responsive ride that can only come from Titanium

■ High performance trail bike components including XT/XTR shifting and FSA BB-30 Afterburner Crank, with Hope X2 brakes

■ Ultimate trailbike finishing kit, including Thomson stem, Thomson seatpost, Easton Haven Carbon XC handlebar and Fizik gobi XM saddle

■ Fox F120 RL suspension fork – with 120mm of travel and 15mm QR through axle

■ Unique contemporary frame, featuring superbly shaped rear stays, Whyte adjustable dropouts and Press Fit 30 BB

PF + 30



2011 TRAIL HT WHYTE 19 Ti



# WHYTE 19 ALLOY

TYPICAL USAGE: CROSS COUNTRY, TRAIL



Versatility - that's the key to the 19 Alloy. Svelte enough to race, burly enough to shred, and awarded the Singletrack magazine Editor's Choice. "If I had to choose the fabled one-bike-for-everything, it would be the Whyte 19", he said.





# WHYTE

PERFORMANCE BY DESIGN



■ Light enough to race - tough enough for trails. This is our most versatile hardtail - from the Quantocks to the Alps, the 19 Alloy can do it all.

■ The frame has been upgraded for 2011 to include a tapered steerer tube for increased front end stiffness and Press Fit 30 BB for outstanding power transfer and improved reliability.

■ The unique 19 dropouts allow for geometry adjustment and easy conversion to a single speed.

■ Our choice of Trail bike finishing kit includes Hope brakes, Thompson bar and stem, SRAM shifting, Stans No Tube rims and a Fox Fork.

PF + 30



2011 TRAIL HT WHYTE 19 ALLOY



# WHYTE 19 STEEL

TYPICAL USAGE: CROSS COUNTRY, TRAIL



Classic British Reynolds Steel for an unforgettable ride. Contemporary Whyte Trail geometry for unsurpassed handling. For an unbeatable combination of heritage and performance, look no further than the Whyte 19 Steel.





# WHYTE

PERFORMANCE BY DESIGN



- Using geometry and tubing profiles developed from the 19 Ti and constructed from the finest British made Reynolds tubing, the 19 steel frame stirs the emotions while delivering an addictive, trail-taming ride.
- Whyte's unique adjustable dropouts allow for easy conversion to and from a single speed setup.
- Reynolds 631 steel is extremely tough and air hardened for extra strength in the welded joints.
- Available as a complete bike or frame only.



2011 TRAIL HT    WHYTE 19 STEEL



## WHYTE 19 DROPOUT

AS FEATURED ON THE WHYTE 19 TITANIUM, 19 ALLOY, 19 STEEL

As you might expect from Whyte not even something as simple as the rear dropout is left without a magic touch from our designers. Used on our Ti, Steel and Alloy "19" Trail bikes, our unique dropout system provides geometry adjustment as well as easy conversion to a single speed setup.

The CNC machined rear dropouts allow adjustment of the chainstay length between 415 and 435mm. With the chainstay length increased the bike sits slightly lower giving a more relaxed feel to the ride and providing more stability on steep, technical descents. Shortening the chainstay length raises the bottom bracket height slightly for increased ground clearance, improved climbing and sharper handling in tight, twisty singletrack.

Both dropout plates are engraved with markings to make accurate wheel alignment quick and easy and the stepless adjustment is perfect to accurately tension the chain for a single speed or hub gear set up – with no need to adjust the brake calliper.



## GETTA GRIP

AS FEATURED ON THE WHYTE 146, T-120 S, 19 TI, 19 ALLOY AND 905

Getta Grip has been developed from scratch to improve the way a seatpost is held in the frame. Traditional clamps need to bend the frame to grip the seat post and often bind after long periods of use, as the frame can no longer "remember" its original shape.

The Patented Getta Grip system takes a whole new approach using a pad that fits through a window in the frame - ideal for UK conditions as there is no open slot to let in mud and water. Because the Getta Grip seat clamp only has to hold the seatpost rather than bend the frame, less force is required to operate it. The clamping force is spread more evenly making it ideal for carbon posts and has been officially approved by Easton for use with all their seatposts.





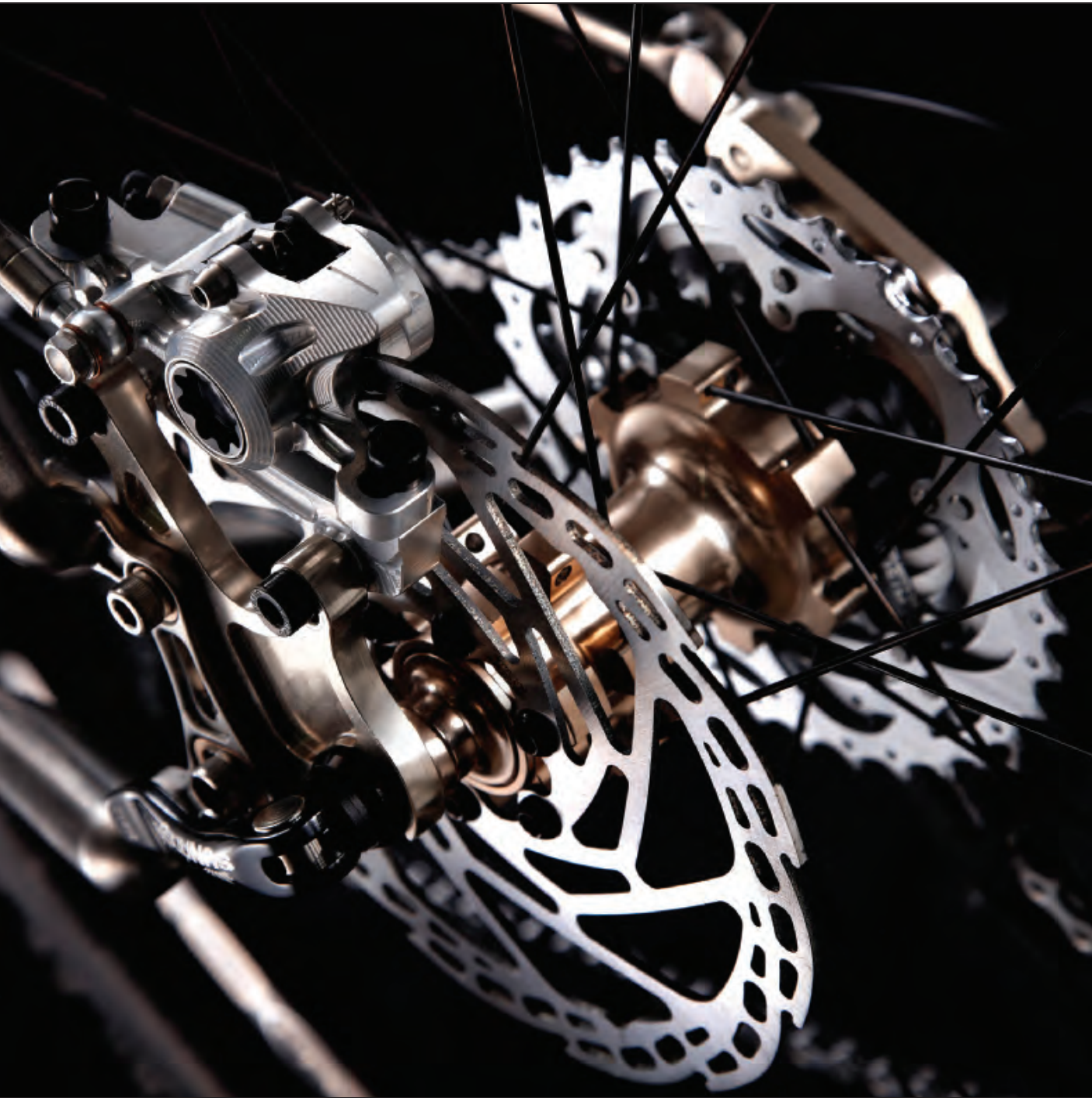





## **WHYTE 905**

TYPICAL USAGE: TRAIL RIDING







# WHYTE 905

TYPICAL USAGE: CROSS COUNTRY, TRAIL



The multi Award-winning 905 is further improved for 2011 with the addition of a tapered headtube. This gives increased steering precision and frame strength.





# WHYTE

PERFORMANCE BY DESIGN



■ Using the same trail geometry developed for the 19, the 905 offers no-compromise performance and sublime handling.

■ The frame is constructed from the highest quality 6061 Aluminum Alloy, extruded and manipulated to our exact specification. The rear seat stays are a work of art internally and contribute in a big way to the 905's outstanding ride characteristics.

■ In a recent review What Mountain Bike Magazine said "it's sharp yet smooth.... a superb blend of race speed and technical confidence", giving it an Editor's Choice and a Gold Award.

■ The upgraded frame for 2011 includes a new tapered headtube and a Press Fit 30 Bottom Bracket for improved long-term performance.

PF  30



2011 TRAIL HT WHYTE 905



# WHYTE 901

TYPICAL USAGE: CROSS COUNTRY, TRAIL

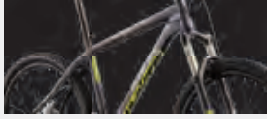

Built from multi butted 6061 tubing using our Whyte 19 Trail geometry the 901 is a fantastic introduction to our Trail hardtail platform.





# WHYTE

PERFORMANCE BY DESIGN



■ Using the same trail geometry developed for the 19, the 901 offers no-compromise performance and sublime handling.

■ The frame is constructed from 6061 Aluminum Alloy, extruded and manipulated to our exact specification.

■ The rear seat stays are precisely shaped and sculpted to help give the 901 excellent ride characteristics.



2011 TRAIL HT WHYTE 901











## X-8 PERFORMANCE XC HARDTAIL

### TYPICAL USAGE: CROSS COUNTRY

They look fast, just standing still.

Climb aboard and you'll see the initial feeling of speed is much more than just an illusion. Our unique geometry fuses cross country agility with trail-honed handling, encouraging you to push your limits on the descents as well as the climbs.

The 805 and 809 offer a perfect introduction to the Whyte brand. Constructed of lightweight butted aluminium and with similar geometry to the acclaimed Carbon hardtails, both bikes are built for thrashing in tough UK conditions. 100mm forks, 2.2 tyres, wide low-rise bars and short stems create a high octaine, trail ready ride that is both responsive and thrilling.

Whether you are riding your local woods, lining up on your 1st race grid or setting the pace with friends at the trail centre the X-8 range is going to deliver.

# WHYTE 809

TYPICAL USAGE: CROSS COUNTRY, RACE



The seat stays perfectly illustrate the quality of our framesets. We have finely honed their shape and internal profile, resulting in outstanding performance and "ride feel"

■ The same high quality frameset features on both bikes. The custom tubing is drawn to our specification and then profiled, butted and shaped to give what we consider to be the perfect ride feel.

■ Our trail-honed geometry is both fast and reassuring, encouraging you to push your limits on the descents as well as the climbs.

■ These frames bristle with UK design features, such as extra mud clearance for all-weather usability, forward facing seat slot to keep rear wheel spray out of the frame, continuous outers for improved cable life and crud-catcher mounts on the downtube to keep the grit out of your teeth.





WHYTE 805



2011 X-8 PERFORMANCE HT 809 and 805







A bicycle is lying on its side on a lush green grassy field. The background is a blurred view of a coastal town with buildings and a sea under a clear blue sky. The bicycle is dark-colored with a black saddle and handlebars. The front wheel is on the left, and the rear wheel is on the right. The frame is dark, and the wheels have black tires with a tread pattern. The overall scene is bright and sunny, suggesting a clear day.

## C7: ALL TERRAIN SERIES

Named after some of the UK's most scenic locations, these All Terrain bikes offer versatility with style. It's all about choice - and this new category from Whyte simply refuses to be pigeonholed. Whether you are touring the lakes, following a canal network or climbing an Alpine Col, the lightweight yet robust range has all your needs covered. The C7 series is also a perfect "Cycle to Work scheme" bike, complete with rack mounts and suspension forks for comfort - or fix on a pannier set and go exploring.

# WHYTE CONISTON

TYPICAL USAGE: ALL TERRAIN - ROAD AND TRAIL



Road meets Trail - our new All Terrain Series is designed to perform faultlessly whether you choose to take the highway or the scenic route through the woods. The All Terrain series is all about choice.





# WHYTE

PERFORMANCE BY DESIGN



■ When we set out to create a range of bikes that would handle all-terrain use we started with the geometry of the frame. 10 years of off-road experience told us that these bikes first and foremost need to handle sweetly, whether riding along a canal tow path, heading down a woodland trail, or beating the traffic on the way through town.

■ A custom rear drop out allows us to fit the hydraulic disc brake caliper inside the rear triangle leaving you plenty of room to fit a rack and mudguards if desired.



2011 C7 ALL TERRAIN CONISTON



# WHYTE CALEDONIAN

TYPICAL USAGE: ALL TERRAIN - ROAD AND TRAIL



Road meets Trail - our new All Terrain Series is designed to perform faultlessly whether you choose to take the highway or the scenic route through the woods. The All Terrain series is all about choice.

- Our custom built frames are loaded with unique design touches and British weatherproof features - such as the forward facing seat slot that stops water spray from the rear wheel getting into the frame and the continuous outer cables that keep the gear shifting working smoother for longer.
- The ride-feel of these bikes is second to none, with a fantastic quality lightweight frame including our unique rear stays which really improve the comfort and performance, whatever the terrain.





WHYTE MALVERN



2011 ALL TERRAIN CALEDONIAN, MALVERN



# WHYTE CALEDONIAN WOMEN'S

TYPICAL USAGE: ALL TERRAIN - ROAD AND TRAIL



Road meets Trail - our new All Terrain Series is designed to perform faultlessly whether you choose to take the highway or the scenic route through the woods. The All Terrain series is all about choice.

- All the same key design features as the Unisex versions, with the added benefit of a partially dropped top tube. This increases standover height, while still keeping enough room inside the frame to comfortably fit a water bottle.
- Another benefit of the partially dropped tube is the maintained stiffness of the frame (fully dropped top tube frames are flexy and offer less steering control)





WHYTE MALVERN  
WOMEN'S



2011 ALL TERRAIN WOMEN'S MODELS





## **R7: FAST URBAN SERIES**

The series name certainly gives a clue to our intentions, but by no means tells the full story. Whyte have defined a new category here, combining the best elements of an Urban MTB, the immediate power delivery of a Road bike and the design flair of a Single Speed.

Our unique geometry balances precise steering control with stability – a perfect combination for life in the fast lane. The frames are mountain-bike tough, to cope with the rigours of the daily commute and super-comfortable so you arrive at work invigorated for the day ahead. Add the uber-clean (and dare we say stylish) look of the new Whyte Fast Urban bikes and you won't just be saving time cutting through town, you'll be stealing a few admiring glances along the way.





# WHYTE MONTPELLIER

TYPICAL USAGE: URBAN, COMMUTE

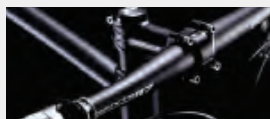

"Less is more" .... Less weight, more speed. Uber-clean lines, precise steering and top-draw spec'ing make the Montpellier the ultimate antidote to the congested city streets. Nothing is left to chance, from the Whyte Union Flag seat collar to the leather lock-on grips and bladed full carbon fork, everything is carefully chosen for quality, performance and style.





# WHYTE

PERFORMANCE BY DESIGN



■ We built an astonishingly good custom frame, then lavished many of the world's best components on the Montpellier.

■ From the bespoke Hope Pro III wheels clad in Vittoria Open Corsa tyres to the SRAM Red Crankset and XX shifting, it's top draw all the way. We've chosen parts that would be outstanding on a Tour-de-France racing thoroughbred, never mind an Urban run around.

■ The Montpellier weighs in at less than 17lbs - unbeatably svelte for a rugged Urban-proof commuter bike.



2011 FAST URBAN MONTPELLIER



# WHYTE STIRLING

TYPICAL USAGE: URBAN, COMMUTE

■ Based on our high performance mountain bike geometry, the Stirling has a long wheelbase and relaxed head angle for high speed stability, and a shorter stem for excellent slow speed manoeuvrability.

■ A custom rear dropout allows us to mount the rear hydraulic disc brake caliper inside the rear triangle, clearing the way for any rack or mudguards that may be required.

■ Our shaped, butted and uniquely profiled rear stays give all our Fast Urban bikes a fantastically responsive and comfortable ride, especially when combined with a top quality carbon fibre front fork.





# WHYTE

PERFORMANCE BY DESIGN



2011 FAST URBAN

WHYTE STIRLING









*Bell's Bicycles, Adventure*

49

# WHYTE CAMBRIDGE

TYPICAL USAGE: URBAN, COMMUTE

- Based on our high performance mountain bike geometry, all our Fast Urban bikes have a long wheelbase and relaxed head angle for high speed stability, and a shorter stem for excellent slow speed manoeuvrability.
- A custom rear dropout allows us to mount the rear hydraulic disc brake caliper inside the rear triangle, clearing the way for any rack or mudguards that may be required.
- Our shaped, butted and uniquely profiled rear stays give all our Fast Urban bikes a fantastically responsive and comfortable ride, especially when combined with a top quality carbon fibre front fork.





# WHYTE

PERFORMANCE BY DESIGN

WHYTE PORTOBELLO



2011 FAST URBAN CAMBRIDGE, PORTOBELLO



# WHYTE 2011

## GEOMETRY:

Geometry – the angles that define the way a bike interacts with the rider and the trail - is the most important part of any bike's character and performance.

It affects every aspect from that welcoming initial confidence, comfort and control to how hard you push yourself hours into a race or what new technical sections you've mastered months after your first ride. Whether it's that crucial traction balance on the crux move of a killer climb or calmly making a turn mm from the edge of potential disaster on a flat out descent, we've designed our bikes to handle superbly in every situation.

Our R&D office uses AutoDesk 3D CAD packages to allow us to conceive, develop and perfect potential geometry before we even get on the trail.

Unlike many manufacturers we rework our geometry for each and every bike too.

- |                    |                    |
|--------------------|--------------------|
| A Head Angle       | B Seat Angle       |
| C Top Tube         | D BB Height        |
| E Stand Over       | F Wheel Base       |
| G Chain Stay       | H Seat Post        |
| I Head tube length | J Seat tube length |

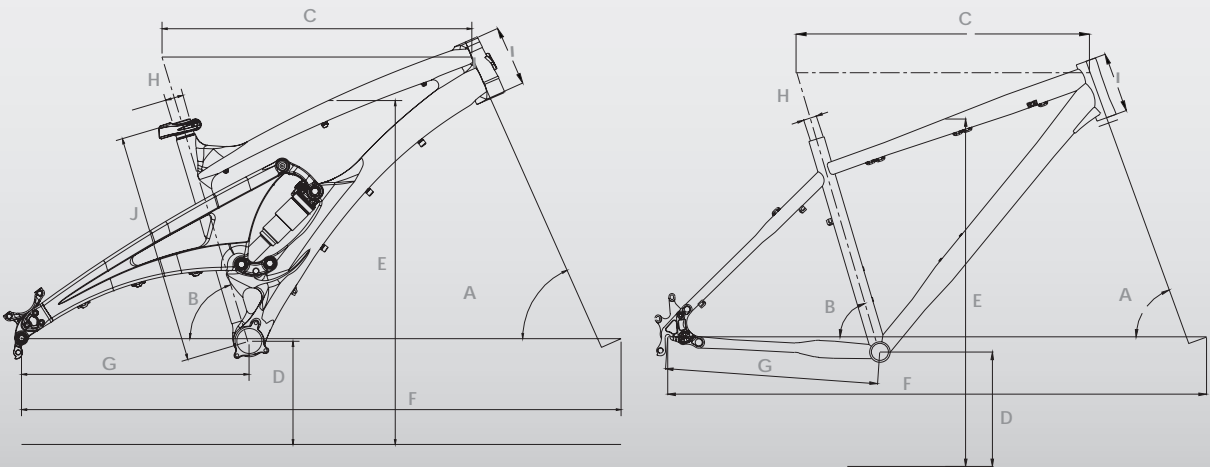

Likely use, likely riders, suspension function, frame attributes – it all affects what angles and dimension will create the optimum character. We also break down each individual aspect of a bike's geometry as well as the components we use so we can isolate and precision tune each vital variable. By co-developing suspension and handling geometry in tandem we can ensure that both work together seamlessly in every situation too.

Finally we build a selection of prototypes for our development team to appraise, prove and perfect in real world trail conditions that no computer simulation can hope to match. It's the feedback of these brutally uncompromising riders as well as our sponsored athletes that give the stamp of true trail authority or send us back to the drawing board again.

After all, if it doesn't ride right, it's not a Whyte.



Whyte 146 Works   Whyte 146 S										
Frame Size	A	B	C	D	E	F	G	H	I	J
Small	66°	73.5°	575.7	338	795	1135.5	440	30.9	115	398.2
Medium	66°	73.5°	599	338	803	1159.4	440	30.9	120	444.7
Large	66°	73.5°	624.4	338	810	1184.8	440	30.9	125	482.6

Whyte T-120S										
Frame Size	A	B	C	D	E	F	G	H	I	J
Small	68°	72.3°	581.7	341.5	756	1093.4	425	27.2	115	419.1
Medium	68°	73°	601.6	336.5	777	1119.3	425	27.2	125	444.5
Large	68°	73.3°	614.3	334.5	800	1135.1	425	27.2	135	482.6

Whyte 19 C Works XX   Whyte 19 Team   Whyte 19 C S   Whyte 19 C										
Frame Size	A	B	C	D	E	F	G	H	I	J
Small	70°	73.5°	576.2	306.5	775	1077.5	420	30.9	134	406.2
Medium	70°	73.5°	600.9	306.5	794	1093	420	30.9	134	454.9
Large	70°	73.5°	614.0	306.5	818	1107.9	420	30.9	144	491.4

Whyte 19 Trail Ti										
Frame Size	A	B	C	D	E	F	G	H	I	J
Small	67.7° - 68.2°	72.2° - 72.7°	565.0	322.7	773 + / - 3.0	1065.3 - 1082.5	425	30.9	100	406.4
Medium	67.7° - 68.2°	72.2° - 72.7°	583.4	322.7	795 + / - 3.0	1085.2 - 1102.4	425	30.9	120	436.4
Large	67.7° - 68.2°	72.2° - 72.7°	609.0	322.7	818 + / - 3.0	1111.1 - 1128.3	425	30.9	125	481.8

Whyte 19 Alloy										
Frame Size	A	B	C	D	E	F	G	H	I	J
Small	67.7° - 68.2°	72.2° - 72.7°	565.1	322.7	774 + / - 3.0	1065.3 - 1082.5	425	30.9	122	406.2
Medium	67.7° - 68.2°	72.2° - 72.7°	584.5	322.7	800 + / - 3.0	1085.2 - 1102.4	425	30.9	132	454.9
Large	67.7° - 68.2°	72.2° - 72.7°	609.6	322.7	826 + / - 3.0	1111.1 - 1128.3	425	30.9	152	491.1

Whyte 19 Trail Steel										
Frame Size	A	B	C	D	E	F	G	H	I	J
Small	67.7° - 68.2°	72.2° - 72.7°	565.0	322.7	776 + / - 3.0	1065.3 - 1082.5	425	30.9	100	406.4
Medium	67.7° - 68.2°	72.2° - 72.7°	583.4	322.7	796 + / - 3.0	1085.2 - 1102.4	425	30.9	120	436.4
Large	67.7° - 68.2°	72.2° - 72.7°	609.0	322.7	823 + / - 3.0	1111.1 - 1128.3	425	30.9	125	481.8

Whyte 905   Whyte 901 Trail										
Frame Size	A	B	C	D	E	F	G	H	I	J
Small	67.5°	72.5°	565.1	322.7	774	1080.7	425	30.9	122	406.2
Medium	67.5°	72.5°	584.5	322.7	800	1100.9	425	30.9	132	454.9
Large	67.5°	72.5°	609.6	322.7	826	1127.6	425	30.9	152	491.1
X-Large	67.5°	72.5°	628.8	322.7	853	1153.8	425	30.9	160	533.4

Whyte 809 | Whyte 805

Frame Size	A	B	C	D	E	F	G	H	I	J
S (16")	68.5°	73.5°	583.8	313.5	773	1091.9	425	30.9	115	406
M (17.5")	68.5°	73.5°	598.5	313.5	797	1107.4	425	30.9	125	444
L (19")	68.5°	73°	617.8	313.5	824	1122.2	425	30.9	135	495
XL (21")	68.5°	73°	628.8	313.5	844	1133.9	425	30.9	145	533

Coniston | Caledonian | Malvern

Frame Size	A	B	C	D	E	F	G	H	I	J
S (16")	69°	74°	592.2	288	784	1100.6	425	30.9	115	406
M (17.5")	69°	73.5°	616.9	288	815	1120.5	425	30.9	125	444
L (19")	69°	73°	631.8	288	842	1130.6	425	30.9	135	495

Caledonian Womens | Malvern Womens

Frame Size	A	B	C	D	E	F	G	H	I	J
Small	68°	68°	559.6	288	720	1072.8	435	30.9	107	431.8
Medium	69°	69°	587.8	288	739	1085.4	435	30.9	115	457
Large	69°	69°	611.4	288	753	1105.4	435	30.9	125	495

Montpellier | Stirling | Cambridge | Portobello (XL is Cambridge and Portobello only)

Frame Size	A	B	C	D	E	F	G	H	I	J
S (16")	69.5°	74°	572.3	271.5	717	1052.2	420	27.2	120	406
M (17.5")	70°	73.5°	596.4	271.5	747	1069.1	420	27.2	140	444
L (19")	70°	73°	611.1	271.5	775	1079.1	420	27.2	160	495
XL (21")	70°	73°	625.1	271.5	805	1094.1	420	27.2	180	533

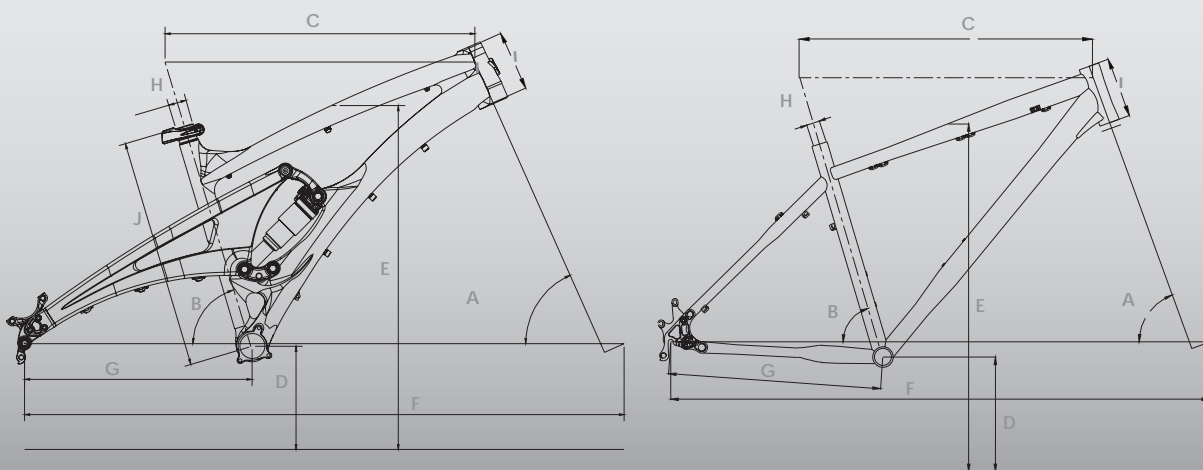

- A Head Angle
- B Seat Angle
- C Top Tube
- D BB Height
- E Stand Over
- F Wheel Base
- G Chain Stay
- H Seat Post
- I Head tube length
- J Seat tube length



	XC FR5			CARBON HT	
Model	Whyte 146 Works	Whyte 146 S	Whyte T-120S	Whyte 19 C Works XX	Whyte 19 Team
Colour	Jet Black / Ghost White / Nickel	Jet Black / Ghost White / Nickel	Gloss Ghost White and Orange	Ghost White, UD Carbon and Acid Green	Ghost White, UD Carbon and Orange
Sizes Available	S, M, L	S, M, L	S, M, L	S, M, L	S, M, L
Frame	Uni-directional Mono-coque Front Triangle, Single Mono-coque Rear Swingarm, Modular Dropouts	Uni-directional Mono-coque Front Triangle, Single Mono-coque Rear Swingarm, Modular Dropouts	Alloy 6061 Front Triangle with Tapered Head Tube, Single Mono-coque Rear Swingarm with Modular Dropouts	High Modulus, Uni-directional Carbon	High Modulus, Uni-directional Carbon
Fork	Fox Float 150 RCL FIT, QR15 Adjustable Rebound and High and Low Speed Compression Adjustment	Fox Float 150 RL FIT, QR15 Adjustable Rebound and Compression Adjustment	RockShox Reba RL, Maxle Light, 120mm Travel, Motion Control Damping with Turn Key Lockout	RockShox SID XX, 100mm Travel, Remote Push-Lock, Motion Control	Fox F100 FIT Damper Cartridge, 100mm Travel, Remote Lockout
Rear Shock	Fox Float RP23, with Rebound Adjustment and Adjustable DOHC ProPedal, Whyte Designs Cartridge Bearing Shock Bushings	Fox Float RP2, with Rebound Adjustment and Adjustable DOHC ProPedal, Whyte Designs Cartridge Bearing Shock Bushings	RockShox Monarch TL, with Rebound Adjustment and compression floodgate	N/A	N/A
Headset	FSA Orbit ZS, Sealed Cartridge Bearings, 1.5" Lower, 1 1/8" Upper Bearings	FSA Orbit ZS, Sealed Cartridge Bearings, 1.5" Lower, 1 1/8" Upper Bearings	FSA Orbit ZS, Sealed Cartridge Bearings, 1.5" Lower, 1 1/8" Upper Bearings	FSA Integrated, Orbit CE Plus, ZS, Sealed Cartridge Bearings	FSA Integrated, Orbit CE Plus, ZS, Sealed Cartridge Bearings
Rear Hub	Easton EA-90 12mm X 142 Shimano E-Thru	SunRingle Black Flag Pro Wheelset, 12mm x 142mm E-Thru	Alloy, Double Sealed Bearing Hub, 32 Hole, 12mm x 142mm Maxle	Easton EA-90, Tubeless Compatible Wheelset	Shimano XTR WH-M985 Wheelset, Tubeless Compatible
Front Hub	Easton EA-90 QR15	SunRingle Black Flag Pro Wheelset, 15QR	Alloy, Double Sealed Bearing Hub, 32 Hole, 20mm Maxle	Easton EA-90, Tubeless Compatible Wheelset	Shimano XTR WH-M985 Wheelset, Tubeless Compatible
Spokes	Easton Double Butted	WheelSmith Double Butted	WTB Double Butted, Black Stainless	Easton Double Butted	Shimano XTR
Rims	Easton EA-90, Tubeless Compatible Wheelset	Stan's No Tubes BST System	WTB Speed Disc, 19mm, 32 Hole	Easton EA-90, Tubeless Compatible Wheelset	Shimano XTR WH-M985 Wheelset, Tubeless Compatible
Tyres	Maxxis Ardent 26 x 2.25" 120 TPI with Kevlar Bead Front, Maxxis Crossmark 2.1" 120 TPI Rear	Maxxis Ardent 26 x 2.25" 120 TPI with Kevlar Bead Front, Maxxis Crossmark 2.1" 120 TPI Rear	WTB Wolverine 26" x 2.2" with Kevlar Bead Front, WTB Wolverine 26" x 2.1" with Kevlar Bead Rear	Maxxis Aspen 26" x 2.1", DKFW AR 465g	Maxxis Aspen 26" x 2.25", DK60 AR Folding Bead
Shift Levers	SRAM XX, 10 Speed	SRAM X-9, 10 Speed	SRAM X-7, 10 Speed	SRAM XX, 10 Speed	Shimano XTR SL-M980, 10 Speed
Front Derailleur	SRAM XX, 10 Speed	SRAM X-9, 10 Speed	SRAM X-7, 10 Speed	SRAM XX, 10 Speed	Shimano XTR FD-M985, 10 Speed
Rear Derailleur	SRAM XX Long Cage, 10 Speed	SRAM X-0 Long Cage, 10 Speed	SRAM X-9 Long Cage, 10 Speed	SRAM XX, 10 Speed	Shimano XTR RD-M980, 10 Speed
Cassette	SRAM XX, 11-36T, 10 Speed	SRAM PG-1050, 12-36, 10 Speed	SRAM PG-1030, 12-36, 10 Speed	SRAM XX, 11-36T, 10 Speed	Shimano XTR CS-M980, 11-34, 10 Speed, Compact Double
Chain	SRAM, 10 Speed	SRAM, 10 Speed	SRAM, 10 Speed	SRAM PC-1030, 10 Speed	FSA Team Issue, 10 Speed
Crankset	SRAM XX Press Fit-30, 26-39, 10 Speed, Compact Double	SRAM X-9 Press Fit-30, 26-39, 10 Speed, Compact Double	SRAM S1400, 26-39, 10 Speed, Compact Double	FSA K-Force, BB-30, 27-39, 10 Speed, Compact Double	FSA SLK Carbon 42-27, 10 Speed, Double
Bottom Bracket	Press Fit-30	Press Fit-30	GXP	BB30	FSA BB30
Seatpost	Rock Shox REVERB Remotely Adjustable, 30.9mm x 420mm	Truvativ Team, 30.9mm x 400mm	Whyte Alloy 2014, 30.9mm x 410mm	FSA K-Force SB0, 27.2mm	Fizik Cyrano, 30.9mm
Seat	Fizik Gobi Chalk White and Black	Fizik Gobi XM	Whyte Custom	Fizik Tundra II, Ti Rails	Fizik Tundra II, Mag Rails
Bar	Easton Haven Carbon Low Rise, 31.8mm OD, 711mm Wide	Easton Haven Alloy Low Rise, 31.8mm, 711mm Wide	Whyte Low Rise 20mm, 31.8mm, 680mm Wide	FSA K-Force Light, Flat Nano Carbon, 31.8mm OD, 600mm Wide	FSA SLK Carbon Flat, 31.8mm, 620mm Wide
Stem	Easton Haven, 31.8mm Bar Clamp, 70mm S, 70mm M, 85mm L	Truvativ Race, S 65mm, M 75mm, L 90mm	Whyte, 31.8mm Bar Clamp, S 70mm, M 80mm, L 90mm	FSA K-Force Carbon, -6 degree, 90mm S/M, 100mm L	FSA SLK, 80mm S, 90mm M, 100mm L
Grips	Whyte Semi Lock-on	Whyte Semi Lock-on	Whyte Semi Lock-on	Whyte Custom Lock-on	Whyte Custom Lock-on
Front Brake	Avid Elixir CR, 180mm Rotor	Avid Elixir R, 185mm Rotor	Avid Elixir 3, 160mm Rotor	SRAM XX, 160mm Rotor	Shimano XTR BL-M985, 160mm Rotor
Rear Brake	Avid Elixir CR, 160mm Rotor, Direct Mount	Avid Elixir R, 160mm Rotor	Avid Elixir 3, 160mm Rotor	SRAM XX, 160mm Rotor	Shimano XTR BL-M985, 160mm Rotor
Brake Levers	Avid Elixir CR Matchmaker	Avid Elixir R Matchmaker	Avid Elixir 3 Matchmaker	SRAM XX Carbon Levers	Shimano XTR BL-M985
Pedals	None	None	None	None	None

Specification details were correct at the time of printing. However, product changes may occur after this time. Please check model availability and full specification details with your dealer prior to ordering.

	CARBON HT		TRAIL HT		
Model	Whyte 19 C S	Whyte 19 C	Whyte 19 Trail Ti	Whyte 19 Alloy	Whyte 19 Trail Steel
Colour	Ghost White, UD Carbon and Pacific Blue	Ghost White, UD Carbon and Apple Green	Brushed Raw Ti	Satin Chalk and Gloss Nickel	Matte Titanium and Nickel
Sizes Available	S, M, L	S, M, L	S, M, L	S, M, L	S, M, L
Frame	High Modulus, Uni-directional Carbon	Uni-directional Multi Monoque	3AL2.5V Aerospace Grade Titanium Alloy, Custom Cold-drawn	6061 Hydro Formed T6 Aluminium, Custom Drawn and Multi Butted, with Press Fit BB Shell, Tapered Headtube and Adjustable Modular Dropouts	Reynolds 631 Air Hardening Steel, Custom Drawn and Multi Butted
Fork	RockShox SID RLT, 100mm Travel, Remote Poploc	Rockshox Reba RL, 100mm Travel, Poploc Remote Lockout	Fox F120RL FIT Cartridge, 120mm Travel, QR15 Dropouts	Fox F120 RL, 120mm Travel, QR15 Dropouts and Tapered Steerer Tube	Fox 32 ALPS RL, 120mm Travel, 9mm Skewer
Headset	FSA Integrated Headset, Orbit CE Plus ZS, Sealed Cartridge Bearings	FSA Orbit CE, Integrated	FSA Orbit MX, Sealed Cartridge Bearings	FSA Orbit ZS, Sealed Cartridge Bearings, 1.5" Lower, 1.8" Upper Bearings	FSA Orbit MX, Sealed Cartridge Bearings
Rear Hub	Fulcrum Red Metal 3 Wheelset, 6 Bolt, Tubeless Compatible	Fulcrum Red Metal 5 Wheelset, 6 Bolt	SunRingle Black Flag Pro Wheelset, 9mm Skewer	SunRingle Black Flag Pro Wheelset, 9mm Skewer	Hope Pro 2, 32 Hole with Shimano XT QR
Front Hub	Fulcrum Red Metal 3 Wheelset, 6 Bolt Hubs, Tubeless Compatible	Fulcrum Red Metal 5 Wheelset, 6 Bolt Hubs	SunRingle Black Flag Pro Wheelset, 15mm Through Axle	SunRingle Black Flag Pro Wheelset, 15mm Through Axle	Alloy, Sealed Bearings with Shimano QR
Spokes	Fulcrum Red Metal 3	Fulcrum Red Metal 5	Wheelsmith Double Butted	Wheelsmith Double Butted	DT Competition Butted 1.8-1.6-1.8mm, Black Stainless with Brass Nipples
Rims	Fulcrum Red Metal 3, Tubeless Compatible	Fulcrum Red Metal 5	Stan's No Tubes BST System	Stan's No Tubes BST System	Mavic XM 317, 32 Hole
Tyres	Continental Race King 26" x 2.0"	Continental Race King 26" x 2.0"	Maxxis Aspen 26" x 2.25" DKFW AR	Maxxis Aspen 26" x 2.25" DK60 AR	Maxxis Aspen 26" x 2.25", DK60 AR Folding Bead
Shift Levers	SRAM X-0, 10 Speed	SRAM X-7, 10 Speed	Shimano XTR SL-M980, 10 Speed	SRAM X-9, 10 Speed	Shimano SLX SL-M660, 10 Speed
Front Derailleur	SRAM X-0, 10 Speed	SRAM X-7, 10 Speed	Shimano XT FD-M7710, 10 Speed	SRAM X-9, 10 Speed	Shimano SLX FD-M660
Rear Derailleur	SRAM X-0 Medium Cage, 10 Speed	SRAM X-7 Carbon Medium Cage, 10 Speed	Shimano XTR RD-M980, 10 Speed	SRAM X-0 Medium Cage, 10 Speed	Shimano SLX RD-663
Cassette	SRAM PG-1070, 11-32, 10 Speed	SRAM PG-1050, 11-32, 10 Speed, Compact Double	Shimano XT SC-M771, 11-34, 10 Speed	SRAM PG-1070, 12-36, 10 Speed	Shimano SLX CS-HG81, 11-34
Chain	FSA Team Issue, 10 Speed	FSA Team Issue, 10 Speed	Shimano CN-HG94, 10 Speed	SRAM PC-1050, 10 Speed	Shimano CN-HG74
Crankset	FSA SLK, BB30, 42-27, 10 Speed, Compact Double	FSA Comet BB30, 42-27, 10 Speed, Double	FSA Afterburner Crankset BB30, 42-32-24, 10 Speed	SRAM FC X-9, 39-26, 10 Speed, Compact Double	FSA V Drive BB30, 42-32-24, 10 Speed
Bottom Bracket	FSA BB30	FSA BB30	SRAM Press Fit BB	SRAM Press Fit-30	FSA BB30
Seatpost	Fi'zi:k Cyrano, 30.9mm	Whyte Custom, 30.9mm x 400mm	Thomson 16 Degree Lay-Back, 30.9mm x 410mm	Thomson 16 Degree Lay-Back, 30.9mm x 410mm	Whyte Custom, 30.9mm
Seat	Fi'zi:k Tundra II, Mag Rails	Whyte Custom	Fi'zi:k Gobi XM, Mag Rails	Fi'zi:k Gobi XM, Mag Rails	Fi'zi:k Gobi XM, Mag Rails
Bar	FSA SLK Carbon Flat, 31.8mm, 620mm Wide	Whyte Custom, Low Rise, 680mm Wide	Easton Haven Carbon XC Low Rise, 31.8mm OD	Easton EA70, Low Rise, 31.8mm, 685mm Wide	Truvative Stylo Race, 31.8mm OD, 25.4mm Rise, 680mm Wide
Stem	FSA SLK, 80mm S, 90mm M, 100mm L	Whyte Custom, 70mm S/M and 80mm L	Thomson Elite X-4, 31.8mm, 70mm S, 80mm M, 90mm L	Thomson 31.8mm, 70mm S, 80mm M, 90mm L	Truvative Stylo Race, 60mm S, 75mm M, 90mm L
Grips	Whyte Custom Lock-on	Whyte Custom Lock-on	Whyte Custom Lock-on	Whyte Custom Lock-on	Whyte Custom Lock-on
Front Brake	Hayes Stroker Carbon, V6 Rotor	Avid Elixir 3, 160mm Rotor	Hope X2, with Hope Tech Levers, 183mm Rotor	Hope X2, with Tech Carbon Levers, 180mm Rotor	Avid Elixir 5, 180mm Rotor
Rear Brake	Hayes Stroker Carbon, V6 Rotor	Avid Elixir 3, 160mm Rotor	Hope X2, with Hope Tech Levers, 160mm Rotor	Hope X2, with Tech Carbon Levers, 160mm Rotor	Avid Elixir 5, 160mm Rotor
Brake Levers	Hayes Stroker Carbon	Avid Elixir 3	Hope Tech Carbon Levers	Hope Tech Carbon Levers	Avid Elixir 5
Pedals	None	N/A	None	None	None

Specification details were correct at the time of printing. However, product changes may occur after this time. Please check model availability and full specification details with your dealer prior to ordering.



	TRAIL HT		ALLOY PERFORMANCE HT		C7 ALL TERRAIN
Model	Whyte 905	Whyte 901 Trail	Whyte 809	Whyte 805	Coniston
Colour	Satin Ghost White with Gloss Orange	Satin Granite Black with Gloss Lime Green	Gloss Jet Black/Ghost White and Orange	Gloss Jet Black/Ghost White and Apple Green	Satin Granite with Orange
Sizes Available	S, M, L, XL	S, M, L, XL	S, M, L, XL	S, M, L, XL	S, M, L
Frame	6061 Hydro Formed T6 Aluminium, Custom Drawn and Multi Butted, with Press Fit BB Shell and Tapered Headtube	6061 Hydro Formed T6 Aluminium, Custom Drawn and Multi Butted	6061 Hydro Formed T6 Aluminium, Custom Drawn and Multi Butted	6061 Hydro Formed T6 Aluminium, Custom Drawn and Multi Butted	6061 Hydro Formed T6 Aluminium, Custom Drawn, Multi Butted with Custom Whyte Dropouts
Fork	RockShox Reba RL, Maxle Light, 120mm Travel, Motion Control Damping with Turn Key Lockout	RockShox Recon TK, Maxle Light 120mm Travel, Solo Air, Adjustable Compression	RockShox Recon Gold RL, 100mm Travel, Solo Air, Adjustable Compression	RockShox Recon Silver TK, 100mm Travel, Adjustable Rebound, Turn Key Lockout	RST Vogue Pro Air, 60mm Travel, Hydro Lockout, Rebound Control and Alloy Steerer
Headset	FSA Orbit ZS, Sealed Cartridge Bearings, 1.5" Lower, 1 1/8" Upper Bearings	FSA Semi Integrated, 1 1/8" Sealed Cartridge Bearings	FSA Semi Integrated, 1 1/8" Sealed Cartridge Bearings	FSA Semi Integrated, 1 1/8" Sealed Cartridge Bearings	FSA Semi Integrated, 1 1/8" Sealed Cartridge Bearings
Rear Hub	Hope II Pro Disc, 32 Hole with Shimano XT QR	Alloy, Double Sealed Bearing Hub, 32 Hole	SRAM 506 Alloy, Double Sealed Bearing Hub, 32 Hole	Alloy, Double Sealed Bearing Hub, 32 Hole	SRAM 506 Alloy, Double Sealed Bearing Hub, 32 Hole
Front Hub	Alloy, Double Sealed Bearing Hub 20mm, 32 Hole	Alloy, Double Sealed Bearing Hub 20mm Through Axle, 32 Hole	SRAM 506 Alloy, Double Sealed Bearing Hub, 32 Hole	Alloy, Double Sealed Bearing Hub, 32 Hole	SRAM 506 Alloy, Double Sealed Bearing Hub, 32 Hole
Spokes	DT Competition Butted 1.8-1.6-1.8mm, Black Stainless with Brass Nipples	WTB 1.8mm, Black Stainless with Brass Nipples	WTB 1.8mm, Black Stainless with Brass Nipples	WTB 1.8mm, Black Stainless with Brass Nipples	DT competition 1.8/1.6/1.8mm, Black Stainless with Brass Nipples
Rims	Mavic XM 317, 32 Hole	Mavic XM 119 Disc Noir, 32 Hole	Mavic XM 119 Disc Noir, 32 Hole	Alex TD-24, 32 Hole	Alex EN-24 700c, 32 Hole with Eyelets
Tyres	Maxxis Aspen 26" x 2.25", DK60 AR Folding Bead	Continental Trail King Fold 26" x 2.2"	Continental Trail King Fold 26" x 2.2"	Continental Trail King Wire 26" x 2.2"	WTB All Terrain Comp 700 x 35c, Folding with Reflective Sidewall and Puncture Belt
Shift Levers	SRAM X-7, 10 Speed	SRAM X-7, 10 Speed	SRAM X-7, 10 Speed	Shimano Alivio, 9 Speed	Shimano Deore, 9 Speed
Front Derailleur	SRAM X-7, 10 Speed	SRAM X-7, 10 Speed	SRAM X-7, 10 Speed	Shimano Alivio, 9 Speed	Shimano Deore, 9 Speed
Rear Derailleur	SRAM X-9, 10 Speed	SRAM X-7 Long Cage, 10 Speed	SRAM X-7 Carbon Medium Cage, 10 Speed	Shimano SLX Shadow, 9 Speed	Shimano XT Shadow, 9 Speed
Cassette	SRAM PG-1050, 12-36, 10 Speed	SRAM PG-1050, 12-36, 10 Speed	SRAM PG-1050, 12-32, 10 Speed	Shimano HG-61, 11-34, 9 Speed	SRAM PG-950, 11-32, 9 Speed
Chain	SRAM PC-1050	SRAM PC-1030, 10 Speed	SRAM PC-1030, 10 Speed	Shimano HG-53, 9 Speed	Shimano HG-53
Crankset	SRAM X9 Press Fit-30, 26-39, 10 Speed, Compact Double	SRAM FC S1000, GXP, 44-33-22, 10 Speed	SRAM FC S1000, GXP, 44-32-22, 10 Speed	Shimano M521, 44-32-22, 9 Speed	Shimano M660 SLX, Hollow Tech II, 48-36-26, 9 Speed
Bottom Bracket	SRAM Press Fit-30	SRAM GXP	SRAM GXP	Shimano BB-ES25 Square Taper	Hollow Tech II
Seatpost	Whyte 20mm Offset, 30.9mm x 400mm, 2014 Alloy	Whyte 20mm Offset, 30.9mm x 400mm, 2014 Alloy	Whyte 20mm Offset, 30.9mm x 400mm, 2014 Alloy	Whyte 20mm Offset, 30.9mm x 400mm, 2014 Alloy	Whyte 20mm Offset, 30.9mm x 400mm, 2014 Alloy
Seat	Fi'zi:k Gobi XM, Mag Rails	Whyte Custom	Whyte Custom	Whyte Custom	Whyte Custom
Bar	SRAM Stylo, 31.8mm, 680mm Wide	SRAM Stylo Race, 31.8mm, 25.4mm Rise, 680mm Wide	Whyte Low Rise 20mm, 31.8mm, 680mm Wide	Whyte Low Rise 20mm, 31.8mm, 680mm Wide	Whyte High Rise 30mm, 31.8mm, 620mm Wide
Stem	SRAM Sylo Race, 70mm S, 80mm M, 90mm L	Whyte Custom, 70mm S, 80mm M, 90mm L	Whyte Custom, 70mm S, 70mm M, 80mm L	Whyte Custom, 70mm S, 70mm M, 80mm L	Whyte Custom, 70mm S, 80mm M, 90mm L
Grips	Whyte Custom Lock-on	Whyte Custom Lock-on	Whyte Custom Lock-on	Whyte Custom Lock-on	Whyte Custom Comfort Lock-on
Front Brake	Avid Elixir 5, 180mm Rotor	Avid Elixir 5, 180mm Rotor	Avid Elixir 3, 160mm Rotor	Hayes Stroker Comp, V6 Rotor	Avid Elixir 3, 160mm Rotor
Rear Brake	Avid Elixir 5, 160mm Rotor	Avid Elixir 5, 160mm Rotor	Avid Elixir 3, 160mm Rotor	Hayes Stroker Comp, V6 Rotor	Avid Elixir 3, 160mm Rotor
Brake Levers	Avid Elixir 5	Avid Elixir 5	Avid Elixir 3	Hayes Stroker Comp	Avid Elixir 3
Pedals	None	None	VP Full Alloy with Toe Clip	VP Composite with Alloy Cage and Toe Clip	VP Full Alloy with Toe Clip

Specification details were correct at the time of printing. However, product changes may occur after this time. Please check model availability and full specification details with your dealer prior to ordering.

C7 ALL TERRAIN				
Model	Caledonian	Malvern	Caledonian Womens	Malvern Womens
Colour	Gloss Ghost White with Pacific Blue	Gloss Jet Black with Apple Green	Gloss Ghost White with Metallic Green	Gloss Jet Black with Varsity Blue
Sizes Available	S, M, L	S, M, L	S, M, L	S, M, L
Frame	6061 Hydro Formed T6 Aluminium, Custom Drawn, Multi Butted with Custom Whyte Dropouts	6061 Hydro Formed T6 Aluminium, Custom Drawn, Multi Butted with Custom Whyte Dropouts	6061 Hydro Formed T6 Aluminium, Custom Drawn, Multi Butted with Custom Whyte Dropouts	6061 Hydro Formed T6 Aluminium, Custom Drawn, Multi Butted with Custom Whyte Dropouts
Fork	SR Suntour NCX-E LO Lite, 63mm travel, Hydro Lockout and Internal Rebound Control	RST Neon Pro, 60mm Travel, Hydro Lockout	SR Suntour NCX-E LO Lite, 63mm travel, Hydro Lockout and Internal Rebound Control	RST Neon Pro, 60mm Travel, Hydro Lockout
Headset	FSA Semi Integrated, 1 1/8" Sealed Cartridge Bearings	FSA Semi Integrated, 1 1/8" Sealed Cartridge Bearings	FSA Semi Integrated, 1 1/8" Sealed Cartridge Bearings	FSA Semi Integrated, 1 1/8" Sealed Cartridge Bearings
Rear Hub	Alloy, Double Sealed Bearing Hub, 32 Hole	Alloy, Double Sealed Bearing Hub, 32 Hole	Alloy, Double Sealed Bearing Hub, 32 Hole	Alloy, Double Sealed Bearing Hub, 32 Hole
Front Hub	Alloy, Double Sealed Bearing Hub, 32 Hole	Alloy, Double Sealed Bearing Hub, 32 Hole	Alloy, Double Sealed Bearing Hub, 32 Hole	Alloy, Double Sealed Bearing Hub, 32 Hole
Spokes	WTB 1.8mm, Black Stainless with Brass Nipples	WTB 1.8mm, Silver Stainless with Brass Nipples	WTB 1.8mm, Black Stainless with Brass Nipples	WTB 1.8mm, Silver Stainless with Brass Nipples
Rims	Alex TD-24 700c, 32 Hole	Alex TD-24 700c, 32 Hole	Alex TD-24 700c, 32 Hole	Alex TD-24 700c, 32 Hole
Tyres	WTB All Terrain Comp 700 x 35c	WTB All Terrain Comp 700 x 35c	WTB All Terrain Comp 700 x 35c	WTB All Terrain Comp 700 x 35c
Shift Levers	Shimano Alivio, 9 Speed	Shimano Alivio, 9 Speed	Shimano Alivio, 9 Speed	Shimano Alivio, 9 Speed
Front Derailleur	Shimano Deore, 9 Speed	Shimano Alivio, 9 Speed	Shimano Deore, 9 Speed	Shimano Alivio, 9 Speed
Rear Derailleur	Shimano SLX Shadow, 9 Speed	Shimano Alivio, 9 Speed	Shimano SLX Shadow, 9 Speed	Shimano Alivio, 9 Speed
Cassette	Shimano Deore HG-50, 11-32, 9 Speed	Shimano Alivio HG-30, 11-32, 9 Speed	Shimano Deore HG-50, 11-32, 9 Speed	Shimano Alivio HG-30, 11-32, 9 Speed
Chain	Shimano HG-53	Shimano HG-53	Shimano HG-53	Shimano HG-53
Crankset	Shimano Deore M443, 48-36-26, Octalink	Shimano M431 Alivio, 48-36-26	Shimano Deore M443, 48-36-26, Octalink	Shimano M431 Alivio, 48-36-26
Bottom Bracket	Shimano ES-25 Octalink	Square Taper	Shimano ES-25 Octalink	Square Taper
Seatpost	Whyte 20mm Offset, 30.9mm x 400mm, 6061 Alloy	Whyte 20mm Offset, 30.9mm x 400mm, 6061 Alloy	Whyte 20mm Offset, 30.9mm x 400mm, 6061 Alloy	Whyte 20mm Offset, 30.9mm x 400mm, 6061 Alloy
Seat	Whyte Custom	Whyte Custom	Whyte Custom Womens Fit	Whyte Custom Womens Fit
Bar	Whyte High Rise 30mm, 31.8mm, 620mm Wide	Whyte High Rise 30mm, 31.8mm, 620mm Wide	Whyte High Rise 30mm, 31.8mm, 620mm Wide	Whyte High Rise 30mm, 31.8mm, 620mm Wide
Stem	Whyte Custom, 70mm S, 80mm M, 90mm L	Whyte Custom, 70mm S, 80mm M, 90mm L	Whyte Custom, 70mm S, 80mm M, 90mm L	Whyte Custom, 70mm S, 80mm M, 90mm L
Grips	Whyte Custom Comfort Lock-on	Whyte Custom Comfort Lock-on	Whyte Custom Comfort Lock-on	Whyte Custom Comfort Lock-on
Front Brake	Hayes Stroker Comp, 160mm Rotor	Tektro Draco, 160mm Rotor	Hayes Stroker Comp, 160mm Rotor	Tektro Draco, 160mm Rotor
Rear Brake	Hayes Stroker Comp, 160mm Rotor	Tektro Draco, 160mm Rotor	Hayes Stroker Comp, 160mm Rotor	Tektro Draco, 160mm Rotor
Brake Levers	Hayes Stroker Comp	Tektro Draco	Hayes Stroker Comp	Tektro Draco
Pedals	VP Composite with Alloy Cage and Toe Clip	VP Composite with Toe Clip	VP Composite with Alloy Cage and Toe Clip	VP Composite with Toe Clip

Specification details were correct at the time of printing. However, product changes may occur after this time. Please check model availability and full specification details with your dealer prior to ordering.



R7 FAST URBAN				
Model	Montpellier	Stirling	Cambridge	Portobello
Colour	Satin Granite Black with Orange	Satin Granite Black with Orange	Satin with Apple Green	Satin Granite Black with Apple Green
Sizes Available	S, M, L	S, M, L	S, M, L, XL	S, M, L, XL
Frame	6061 Hydro Formed T6 Aluminium, Custom Drawn, Multi Butted with Custom Whyte Dropouts and Press Fit BB Shell	6061 Hydro Formed T6 Aluminium, Custom Drawn, Multi Butted with Custom Whyte Dropouts	6061 Hydro Formed T6 Aluminium, Custom Drawn, Multi Butted with Custom Whyte Dropouts	6061 Hydro Formed T6 Aluminium, Custom Drawn, Multi Butted with Custom Whyte Dropouts
Fork	Bladed Full Carbon Front Fork and Steerer, with Double Eyelets and Low Rider Bosses	Bladed Carbon Front Fork with Alloy Steerer Tube, Double Eyelets and Low Rider Bosses	Bladed Carbon Front Fork, with Double Eyelets and Low Rider Bosses	Bladed 6061 Alloy T6 Front Fork, with Double Eyelets and Low Rider Bosses
Headset	FSA Semi Integrated Road, 1 1/8" Sealed Cartridge Bearings	FSA Semi Integrated Road, 1 1/8" Sealed Cartridge Bearings	FSA Semi Integrated Road, 1 1/8" Sealed Cartridge Bearings	FSA Semi Integrated Road, 1 1/8" Sealed Cartridge Bearings
Rear Hub	Hope Pro III Wheelset, 24 Hole	Alloy, Double Sealed Cartridge Bearing Hub, 32 Hole	Alloy, Double Sealed Bearing Hub, 32 Hole	Alloy, Double Sealed Bearing Hub, 32 Hole
Front Hub	Hope Pro III Wheelset, 24 Hole	Alloy, Double Sealed Cartridge Bearing Hub, 28 Hole	Alloy, Double Sealed Bearing Hub, 28 Hole	Alloy, Double Sealed Bearing Hub, 28 Hole
Spokes	Sapin Double Butted, Black Stainless with Alloy Nipples	DT Competition, Black Stainless with Brass Nipples	WTB PG 1.8mm, Black Stainless with Brass Nipples	WTB PG 1.8mm, Black Stainless with Brass Nipples
Rims	DT, Deep Section Road	Alex Race 28, Deep Section Road Rim, 32 Hole Rear and 28 Front	Alex Race 28, Deep Section Road, 32 Hole Rear and 28 Front	Alex Race 28, Deep Section Road, 32 Hole Rear and 28 Front
Tyres	Vittoria, Open Corsa EVO CX, 700 x 23c, Black	Continental Ultra Race, 700 x 25c, Black, with Puncture Protection	Maxxis Detonator, 700 x 28c, Grey, with Puncture Protection	Maxxis Detonator, 700 x 28c, Black, with Puncture Protection
Shift Levers	SRAM XX, 10 Speed	SRAM SL700, 10 Speed	SRAM SL700, 10 Speed	Shimano SL-R440, 9 Speed
Front Derailleur	SRAM Force, 10 Speed	SRAM APEX, 10 Speed	SRAM APEX, 10 Speed	Shimano R440, 9 Speed
Rear Derailleur	SRAM Red Carbon, 10 Speed	SRAM Rival, 10 Speed	SRAM APEX, 10 Speed	Shimano Sora, 9 Speed
Cassette	SRAM OG-1090, 11-28, 10 Speed	SRAM PG-1050, 11-28, 10 Speed	SRAM APEX PG-1050, 11-32	SRAM PG-950, 9 Speed
Chain	SRAM PC-1050	SRAM PC-1030, 10 Speed	SRAM PC-1030, 10 Speed	Shimano HG-53
Crankset	SRAM Red BB-30, 34-50, 10 Speed, Compact	SRAM APEX, 34-50, 10 Speed, Compact	SRAM S150, 34-50, 10 Speed, Compact	FSA Tempo 34-50, 9 Speed, Compact
Bottom Bracket	SRAM Press Fit	SRAM GXP	SRAM Power Spline	FSA Square Taper
Seatpost	Fizik Cyrano, 27.2mm x 350mm	Whyte 20mm Offset, 27.2mm x 350mm, 2014 Alloy	Whyte 20mm Offset, 27.2mm x 350mm, 2014 Alloy	Whyte 20mm Offset, 27.2mm x 350mm, 2014 Alloy
Seat	Fizik Gobi XM	SR Viper, with Scuff Guards	Whyte Custom	Whyte Custom
Bar	Whyte Ultra Narrow, 31.8mm, Flat Bar, 580mm Wide	Whyte Ultra Narrow, 31.8mm, 20mm Rise, 580mm Wide	Whyte Ultra Narrow, 31.8mm, 20mm Rise, 580mm Wide	Whyte Ultra Narrow, 31.8mm, 20mm Rise, 580mm Wide
Stem	Whyte, 70mm S, 80mm M, 90mm L	Whyte, 70mm S, 80mm M, 90mm L	Whyte, 70mm S, 80mm M, 90mm L	Whyte, 70mm S, 80mm M, 90mm L
Grips	Fizik Lock-on Leather	Whyte Custom Lock-on	Whyte Custom Lock-on	Whyte Custom Lock-on
Front Brake	Hope X-2 Race, Matchmaker Clamps	Tektro Volans, 160mm Rotor	Tektro Draco, 160mm Rotor	Tektro Draco, 160mm Rotor
Rear Brake	Hope X-2 Race, Matchmaker Clamps	Tektro Volans, 160mm Rotor	Tektro Draco, 160mm Rotor	Tektro Draco, 160mm Rotor
Brake Levers	Hope X-2 Race	Tektro Volans	Tektro Draco	Tektro Draco
Pedals	None	Full Alloy with Toe Clip	Composite with Alloy Cage and Toe Clip	Composite with Alloy Cage and Toe Clip

Specification details were correct at the time of printing. However, product changes may occur after this time. Please check model availability and full specification details with your dealer prior to ordering.

